

2018 CATALOG & PRICE GUIDE

EFFECTIVE: February 1, 2018 | REVISED: February 7, 2018



HOSHIZAKI

ICE MACHINES ★ REFRIGERATION

hoshizakiamerica.com



CONTENTS

ICE EQUIPMENT

ICE MACHINE MODEL CODE & USAGE GUIDE	3
TYPES OF ICE	4
CUBER SERIES	5
Undercounter Cubers with Built-In Bins	6-7
KMEdge & KM Crescent Cubers	8 -13
KMEdge & KM Crescent Cubers (Dispenser)	14 -15
KMEdge Low Profile Crescent Cubers	16
KM Crescent Cubers - Serenity Series	17-18
IM Square Cubers	19
FLAKER / CUBELET SERIES	20
Undercounter Flakers with Built-In Bins	20-21
Flakers	21-22
Undercounter Cubelet Ice Machines with Built-In Bins	23
Cubelet Ice Machines	23-25
Cubelets - Serenity Series	26
DISPENSER SERIES	27
DCM Series	27-28
DCM Opti-Serve™ Series	28-29
DB Series	30-31
DKM Serenity Series	31
DM Series	31
ICE STORAGE BINS	32-33
DISPENSER STANDS	34
HCD ICE BAGGING SYSTEM	34
TOP KIT MATRIX	35
REMOTE CONDENSER SERIES	36-38
WATER FILTRATION	39
OZONE DEVICE	40

REFRIGERATION

SUSHI CASES	41
REFRIGERATION FEATURES & BENEFITS	42
REFRIGERATION MODEL CODE	44
COMMERCIAL SERIES	45
Upright Refrigerators & Freezers	45-48
Compact Undercounter Refrigerator	49
Undercounter Refrigerators & Freezers	50-52
Undercounter Refrigerators & Freezer with Drawers	53-54
Worktop Refrigerators & Freezers	55-56
Worktop Refrigerators & Freezer with Drawers	57-58
Prep Tables - Sandwich Top Refrigerators	60-61
Prep Tables - Sandwich Top Refrigerators with Drawers	62
Prep Tables - Mega Top Refrigerators	63-64
Prep Tables - Mega Top Refrigerators with Drawers	65
Prep Tables - Pizza Refrigerators	67
Prep Tables - Pizza Refrigerators with Drawers	68
Drawer / Door Combinations	59, 62, 66, 69
Refrigerated Equipment Stands	70
GLASS DOOR MERCHANDISERS	71
REFRIGERATION ACCESSORIES	72-75

Terms and Conditions
Specifications are subject to change without notice.
All rights reserved by HOSHIZAKI AMERICA, INC.

ABOUT HOSHIZAKI



CORPORATE VISION

HOSHIZAKI is a name synonymous with quality, innovation and reliability. These values exist through the vision of our leadership and focus on teamwork... developing quality relationships with our employees, suppliers, distributors, dealers, designers, and service providers. Together, we positively impact the users of our products and the communities in which we live.



CORPORATE LOCATIONS

HOSHIZAKI AMERICA, INC., with corporate headquarters in Peachtree City, Georgia, and a second manufacturing facility in Griffin, Georgia, operates some of the most automated production facilities in the industry. Using state-of-the-art technology, every HOSHIZAKI unit is run-tested at each factory, and undergoes rigorous quality performance tests. HOSHIZAKI offers advanced training seminars at our headquarters and basic training programs across the country for both service representatives and customers.



DID YOU KNOW?

- **HOSHIZAKI** is the world's largest manufacturer of commercial ice equipment, employing over 11,800 people.
- **HOSHIZAKI** is the world's largest manufacturer of commercial refrigerated food service equipment with sales of over \$2.5 billion serving customers in 60 nations.
- **HOSHIZAKI** operates plants worldwide including two in the USA, three in Japan, one each in England and China.
- **HOSHIZAKI** operates sales offices worldwide with distribution throughout 60 nations.
- In expansion to a full-service kitchen equipment company, **HOSHIZAKI** acquired Lancer Corporation in 2006, GRAM Commercial A/S in 2008, and both Jackson and Macom in 2013.
- **HOSHIZAKI** is certified in ISO-9001, ISO-14001 and OSHAS-18001:2007 - being the first and only food service equipment manufacturer to achieve ISO-14001.
- In 2017, **HOSHIZAKI** was awarded "Partner Of The Year - Sustained Excellence" by Energy Star.



ISO9001-ISO14001





WARRANTY

EFFECTIVE: February 1, 2018

Supersedes all previous price lists

TERMS and CONDITIONS

Prices are F.O.B. Factory. All prices and specifications are subject to change without notice. HOSHIZAKI reserves the right to determine point of shipment.

TERMS: Terms are such as the Company may extend to the purchaser.

LOST OR DAMAGED SHIPMENTS: Whenever seller shall deliver or cause to be delivered to a common carrier any goods ordered by consignee, whether the particular common carrier shall have been designated in the shipping instructions of the consignee or not, seller shall not be responsible for any delays or damage in shipment and the common carrier to which seller shall deliver goods shipped to the consignee is hereby declared to the agent of the consignee. Therefore it is the responsibility of the consignee to file claim with the carrier for lost or damaged shipments.

WARRANTY

All units to be free from manufacturing defects, covered by:

KM Series Cubers / IM Series Cubers / DKM Ice Machine & Dispenser and DB / DM Hotel / Motel Dispensers

3-Year - Parts & Labor on entire machine & DB / DM Dispenser

5-Year - Parts & Labor on Evaporator, Parts on Compressor, Air-Cooled Condenser Coil

AM-50 Series Cubers & C-80 Flakers

2-Year - Parts & Labor on entire machine

Flakers and Cubelet Ice Machines, DCM Ice & Water Dispensers

3-Year - Parts & Labor on entire machine.

5-Year - Parts on Compressor, Air-Cooled Condenser Coil

Bins & Water Dispensers

3-Year - Parts & Labor on Slope Front Bins

5-Year - Parts & Labor on Large Upright Bin Models

Countertop Refrigerated Display Cases

1-Year - Parts & Labor on entire machine

2-Year - Parts & Labor on Compressor, Evaporator, Air-Cooled Condenser

5-Year - Parts on Compressor, Air-Cooled Condenser

Accessories

90 Day - Parts only

1-Year - HS-5061 Drain Pump (Beckett Brand) - Parts & Labor

1-Year - Water Filter System & Replaceable Elements

Warranty

Warranty valid in United States, Canada, Puerto Rico, & U.S. Territories only. Contact Factory for warranty in other countries.

Refer to manufacturer's full warranty for complete details. Suggested List Prices are intended only as a guide.

This does not restrict the price seller may establish due to market conditions.

AGENCY LISTINGS and MARKS



CANADIAN ENERGY PERFORMANCE VERIFIED
RENDREMENT ENERGETIQUE VERIFIE

ICE MACHINE MODEL NUMBER IDENTIFICATION CODE

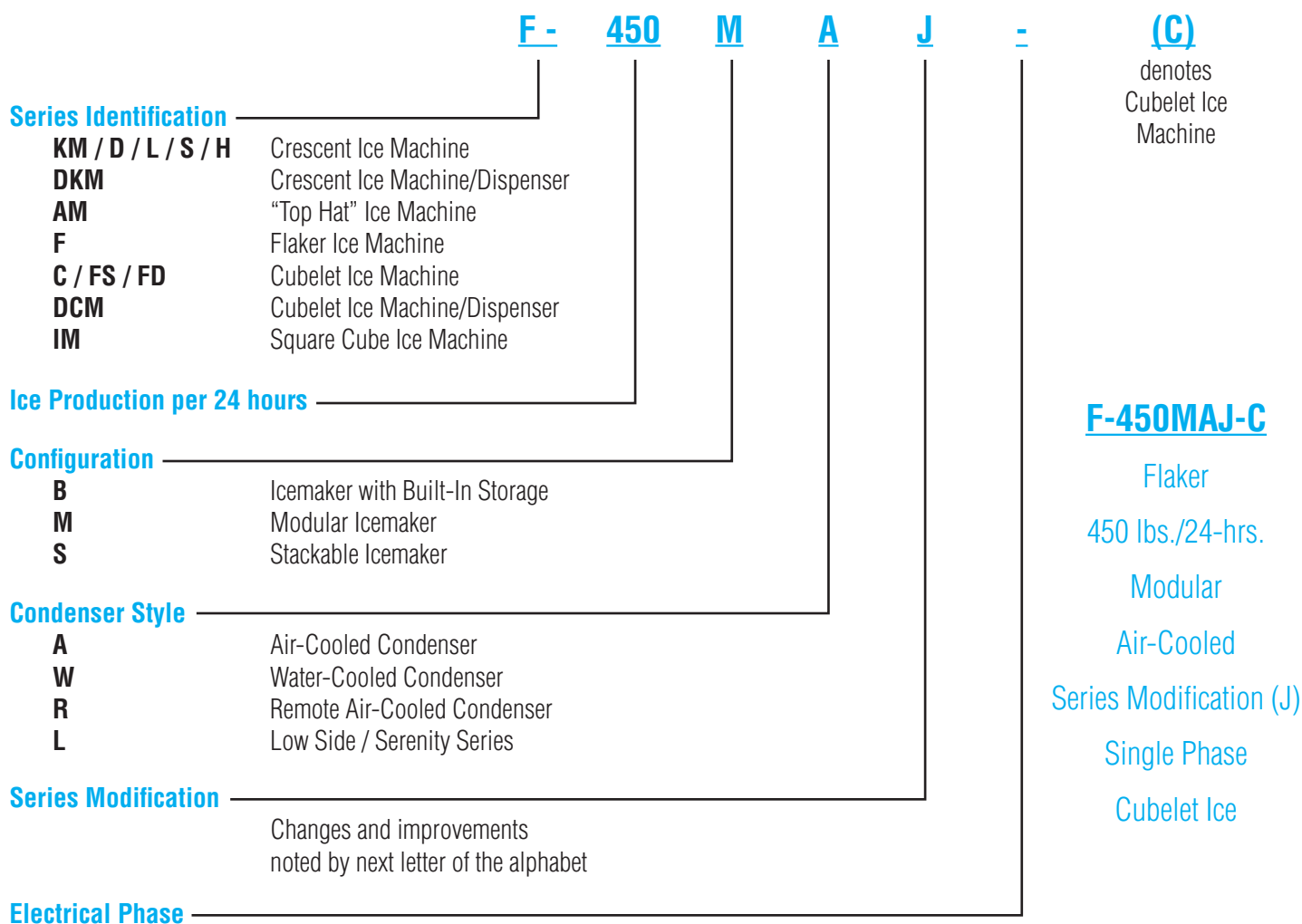

F-450MAJ-C

Flaker
 450 lbs./24-hrs.
 Modular
 Air-Cooled
 Series Modification (J)
 Single Phase
 Cubelet Ice

CUBER ICE USAGE GUIDE

Establishment	Approximate Daily Usage
Restaurant	1.5 lbs. ice per seat
Cocktail Lounge	3.0 lbs. ice per seat
Lodging	
Food Service	1.5 lbs. ice per seat
Banquet Service	1.0 lbs. ice per seat
Guest Ice	5.0 lbs. ice per room
Beverage Service	5.0 oz. ice per 7-10 oz. cup
Convenience Store	8.0 oz. ice per 12-16 oz. cup
Fast Food	10.0 oz. ice per 20-32 oz. cup
Salad Bar/Seafood Display	30 lbs. ice per cubic feet



TYPES OF ICE



Crescent Cube - Individual, hard, clear, crescent shape

Ice Equipment Models:

- KM KMD
- KML KMS
- KMH DKM models

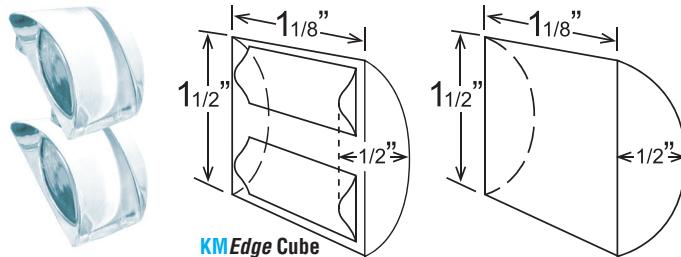

"Top Hat" Cube - Individual, hard, clear, round shape

Ice Equipment Models:

- AM models

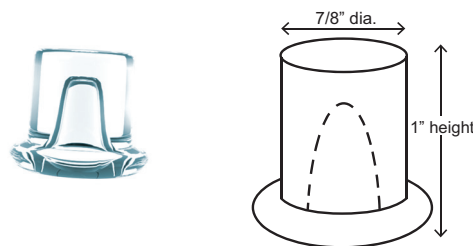

Square Cube - Individual, hard, clear, square shape

Ice Equipment Models:

- IM models

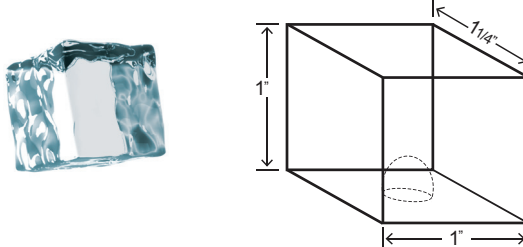

Cubelet - Chewable, soft, light, small pellet shape

Ice Equipment Models:

- C
- FD-C
- F-C
- FS-C
- DCM models

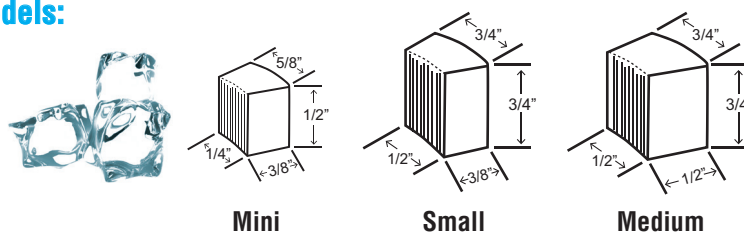

Flaked - Soft, light, chewable, various shapes

Ice Equipment Models:

- F models

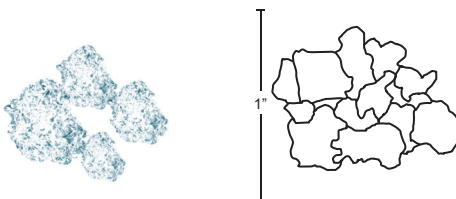

CUBER SERIES



Features & Benefits of the AM Cuber

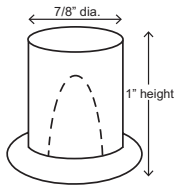

- Attractive stainless steel finish
- Individual top-hat style cubes eliminates clumping and allow for easy filling of glass
- **AM Series Cubers** were designed with fewer moving parts, which contribute to its long life and dependability
- Compact size (less than 34 inches), undercounter design, swing style reversible door, and UL approval for outdoor use of the expand the possibilities where this machine can be installed
- Front in and front out airflow allows unit to be built into cabinetry without additional ventilation
- Ice making compartment can be easily disassembled for cleaning
- Door system is designed to accommodate custom cabinetry
- ADA Compliant



Features & Benefits of the KM Cuber

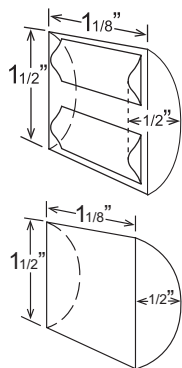

KM Edge DESIGN

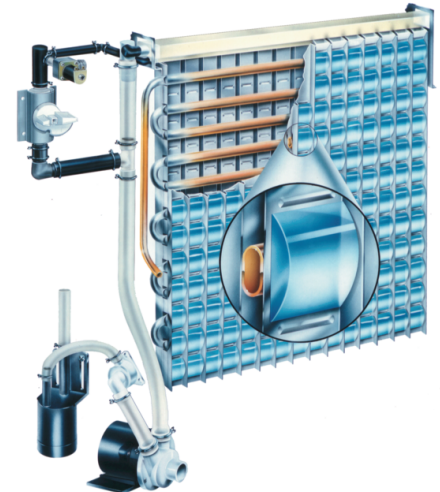

- Benefits include increased productivity and energy savings, even in harsh water conditions
- The **KM Cuber Series** features an attractive stainless steel finish with the simplest ice making system in the industry
- The exclusive dual-sided stainless steel evaporator has oval-shaped copper refrigerant tubing for the most efficient heat exchange
- HOSHIZAKI's evaporator design freezes the purest water, washing most of the minerals and impurities down the drain; resulting in individual crystal clear crescent cubes
- Not affected by caustic water, therefore no plating to peel or flake and no plastic to crack
- Fewer moving parts and cycles means dependability, longer machine life and energy savings
- CycleSaver™ design allows production of the same amount of ice in half the cycles of other ice machines
- EverCheck™ control board sounds an audible warning when service is needed
- Contains H-GUARD Plus® Antimicrobial Agent





CUBER Self Contained

AM-50BAJ

-DS shown with Custom Cabinetry





Undercounter AM Cubers with Built-In Bins

Dimensions: 14 ^{7/8}"W X 22 ^{5/8}"D X 33 ^{1/2}"H
The ADA compliant machine dimensions are 14^{7/8}"W x 22^{5/8}"D x 31^{1/2}" H

Model Number	Condenser	Lbs. of Ice per 24 hours 90°A / 70°W	Lbs. of Ice per 24 hours 70°A / 50°W	Electrical	kWh per 100 Lbs.	Shipping Weight	List F.O.B. Griffin
AM-50BAJ	Air-Cooled	35	51	115V/60/1	10.4	97 Lbs.	\$3,580
AM-50BAJ-DS[†]	Air-Cooled	35	51	115V/60/1	10.4	97 Lbs.	\$3,720
AM-50BAJ-AD*	Air-Cooled	34	49	115V/60/1	9.9	99 Lbs.	\$3,800
AM-50BAJ-ADDS[†]	Air-Cooled	34	55	115V/60/1	9.9	99 Lbs.	\$3,900

Accessories

HS-0229 DS Door Reversal Part (<i>Order as a Service Part</i>)	
HS-5061 Drain Pump (Beckett Brand) 1 Year Warranty - Parts & labor (<i>Order as Accessory</i>)	\$600
HS-0182 Side Trim Kit	\$235
HS-2133 2" Top Spacer Kit available	\$170
H9320-51 Recommended Water Filtration - Single Configuration	\$355







UL approved for outdoor use

[†]DS Models - Wood Door System (Designed to accommodate custom cabinetry)

*ADA compliant

KM-61BAH







Undercounter KM Cuber with Built-In Bin

Dimensions: 17 ^{3/4}"W X 24 ^{1/4}"D X 39*"H
(*6" Legs Included)

Model Number	Condenser	Lbs. of Ice per 24 hours 90°A / 70°W	Lbs. of Ice per 24 hours 70°A / 50°W	Electrical	kWh per 100 Lbs.	Shipping Weight	List F.O.B. Griffin
KM-61BAH	Air-Cooled	50	71	115V/60/1	10.6	121 Lbs.	\$3,120

Accessories

HS-5061 Drain Pump (Beckett Brand) 1 Year Warranty - Parts & labor (<i>Order as Accessory</i>)	\$600
H9320-51 Recommended Water Filtration - Single Configuration	\$355

[†]Rated in accordance with AHRI Standard 820(I-P). Capacity based on 100% of total volume x 30 lb/ft³ average density of ice.

KM-101BAH







Undercounter KM Cuber with Built-In Bin

Dimensions: 23 ^{3/4}"W X 24 ^{1/4}"D X 39*"H
(*6" Legs Included)

Model Number	Condenser	Lbs. of Ice per 24 hours 90°A / 70°W	Lbs. of Ice per 24 hours 70°A / 50°W	Electrical	kWh per 100 Lbs.	Shipping Weight	List F.O.B. Griffin
KM-101BAH	Air-Cooled	88	115	115V/60/1	9.4	143 Lbs.	\$3,520

Accessories





HS-5061 Drain Pump (Beckett Brand) 1 Year Warranty - Parts & labor (<i>Order as Accessory</i>)	\$600
H9320-51 Recommended Water Filtration - Single Configuration	\$355

















[†]Rated in accordance with AHRI Standard 820(I-P). Capacity based on 100% of total volume x 30 lb/ft³ average density of ice.

CUBER Self Contained



KM-151B_H 		Undercounter KM Cuber with Built-In Bin					Self-Contained Bin Storage Capacity Up to 78 Lbs.†		
		Dimensions: 23 3/4" W X 28 1/4" D X 39" H (*6" Legs Included)							
		Model Number	Condenser	Lbs. of Ice per 24 hours 90°A / 70°W	Lbs. of Ice per 24 hours 70°A / 50°W	Electrical	kWh per 100 Lbs.	Shipping Weight	List F.O.B. Griffin
		KM-151BAH	Air-Cooled	121	146	115V/60/1	8.4	156 Lbs.	\$3,960
		KM-151BWH	Water-Cooled	130	146	115V/60/1	7.3	156 Lbs.	\$3,960
Accessories H9320-51 Recommended Water Filtration - Single Configuration \$355									
   Intertek									
†Rated in accordance with AHRI Standard 820(I-P). Capacity based on 100% of total volume x 30 lb/ft³ average density of ice.									

KM-201BAH 		Undercounter KM Cuber with Built-In Bin					Self-Contained Bin Storage Capacity Up to 80 Lbs.†		
		Dimensions: 24" W X 28" D X 39" H (*6" Legs Included)							
		Model Number	Condenser	Lbs. of Ice per 24 hours 90°A / 70°W	Lbs. of Ice per 24 hours 70°A / 50°W	Electrical	kWh per 100 Lbs.	Shipping Weight	List F.O.B. Griffin
		KM-201BAH	Air-Cooled	165	201	115V/60/1	7.5	177Lbs.	\$4,290
Accessories H9320-51 Recommended Water Filtration - Single Configuration \$355									
    Intertek									
†Rated in accordance with AHRI Standard 820(I-P). Capacity based on 100% of total volume x 30 lb/ft³ average density of ice.									

KM-260B_H 		Undercounter KM Cuber with Built-In Bin					Self-Contained Bin Storage Capacity Up to 100 Lbs.†		
		Dimensions: 30" W X 28" D X 39" H (*6" Legs Included)							
		Model Number	Condenser	Lbs. of Ice per 24 hours 90°A / 70°W	Lbs. of Ice per 24 hours 70°A / 50°W	Electrical	kWh per 100 Lbs.	Shipping Weight	List F.O.B. Griffin
		KM-260BAH	Air-Cooled	200	263	115V/60/1	7.6	204 Lbs.	\$4,830
		KM-260BWH	Water-Cooled	237	268	115V/60/1	6.4	204 Lbs.	\$4,830
Accessories H9320-51 Recommended Water Filtration - Single Configuration \$355									
    Intertek									
†Rated in accordance with AHRI Standard 820(I-P). Capacity based on 100% of total volume x 30 lb/ft³ average density of ice.									



CUBER

KM-340M_J

KM Edge Cubers

Dimensions: 22"W X 27 3/8"D X 30 5/16"H
(ice machine dimensions only)

Model Number	Condenser	Lbs. of Ice per 24 hours 90°A / 70°W	Lbs. of Ice per 24 hours 70°A / 50°W	Electrical	kWh per 100 Lbs.	Shipping Weight	List F.O.B. Griffin
KM-340MAJ*	Air-Cooled	315	404	115V/60/1	5.7	159 Lbs.	\$4,920
KM-340MWJ	Water-Cooled	344	402	115V/60/1	4.8	166 Lbs.	\$4,920

Accessories: **H9320-51** Recommended Water Filtration - Single Configuration \$355

***ENERGY STAR qualified**

B-300
22 x 32 1/2 x 76 5/16

B-500
30 x 32 1/2 x 76 5/16

B-700
44 x 32 1/2 x 76 5/16

B-800
48 x 32 1/2 x 76 5/16

B900
52 x 32 1/2 x 76 5/16

Dimensions shown in W x D x H include Bins. See TOP KIT MATRIX (pg 35) for top kit options based on bin size.

KM-515M_J

KM Edge Cubers

Dimensions: 22"W X 27 3/8"D X 30 5/16"H
(ice machine dimensions only)

Model Number	Condenser	Lbs. of Ice per 24 hours 90°A / 70°W	Lbs. of Ice per 24 hours 70°A / 50°W	Electrical	kWh per 100 Lbs.	Shipping Weight	List F.O.B. Griffin
KM-515MAJ*	Air-Cooled	450	517	115V/60/1	5.3	179 Lbs.	\$5,580
KM-515MWJ	Water-Cooled	457	495	115V/60/1	4.5	175 Lbs.	\$5,580
KM-515MRJ	Remote A-C	454	504	115V/60/1	5.1	166 Lbs.	\$5,480

Model Number	Condenser	Kgs. of Ice per 24 hours 32°A / 21°W	Kgs. of Ice per 24 hours 21°A / 10°W	Electrical	kWh per 45 Kgs.	Shipping Weight	List F.O.B. Griffin
KM-515MAH-E	Air-Cooled	185	233	220-240/50/1	7.1	79 Kg.	\$5,580

Accessories: **H9320-51** Recommended Water Filtration - Single Configuration \$355
HS-5243 Tamper Proof Kit - Air Cooled Units \$420
HS-5244 Tamper Proof Kit - Water Cooled Units \$420

***ENERGY STAR qualified**

B-300
22 x 32 1/2 x 76 5/16

B-500
30 x 32 1/2 x 76 5/16

B-700
44 x 32 1/2 x 76 5/16

B-800
48 x 32 1/2 x 76 5/16

B900
52 x 32 1/2 x 76 5/16

Use URC-5F Condenser for Remote Air-Cooled Unit
 "E" suffix designates 50 hertz models
 Dimensions shown in W x D x H include Bins. See TOP KIT MATRIX (pg 35) for top kit options based on bin size.

KM-600MAH

KM Cuber

Dimensions: 22"W X 27 3/8"D X 37 5/16"H
(ice machine dimensions only)

Model Number	Condenser	Lbs. of Ice per 24 hours 90°A / 70°W	Lbs. of Ice per 24 hours 70°A / 50°W	Electrical	kWh per 100 Lbs.	Shipping Weight	List F.O.B. Griffin
KM-600MAH	Air-Cooled	503	592	115-120V/60/1	5.7	200 Lbs.	\$5,970

Accessories: **H9320-52** Recommended Water Filtration - Twin Configuration \$606

B-300
22 x 32 1/2 x 83 5/16

B-500
30 x 32 1/2 x 83 5/16

B-700
44 x 32 1/2 x 83 5/16

B-800
48 x 32 1/2 x 83 5/16

B-900
52 x 32 1/2 x 83 5/16

Dimensions shown in W x D x H include Bins. See TOP KIT MATRIX (pg 35) for top kit options based on bin size.

CUBER



KM-650M_J





KMEdge Cubers

Dimensions: 22"W X 27 ^{3/8}"D X 30 ^{5/16}"H
(ice machine dimensions only)



Model Number	Condenser	Lbs. of Ice per 24 hours 90°A / 70°W	Lbs. of Ice per 24 hours 70°A / 50°W	Electrical	kWh per 100 Lbs.	Shipping Weight	List F.O.B. Griffin
KM-650MAJ	Air-Cooled	562	630	115V/60/1	5.4	176 Lbs.	\$6,480
KM-650MWJ	Water-Cooled	635	647	115V/60/1	4.4	176 Lbs.	\$6,480
KM-650MRJ	Remote A-C	564	632	115V/60/1	5.3	170 Lbs.	\$6,270
Model Number	Condenser	Kgs. of Ice per 24 hours 32°A / 21°W	Kgs. of Ice per 24 hours 21°A / 10°W	Electrical	kWh per 45 Kgs.	Shipping Weight	List F.O.B. Griffin
KM-650MAH-E	Air-Cooled	230	296	220-240/50/1	5.7	91 Kg.	\$6,480

Accessories: H9320-52 Recommended Water Filtration - Twin Configuration \$606

Use URC-5F Condenser for Remote Air-Cooled Unit

"E" suffix designates 50 hertz models



B-300

22 x 32 1/2 x 76 5/16

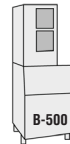

B-500

30 x 32 1/2 x 76 5/16

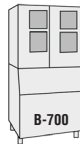

B-700

44 x 32 1/2 x 76 5/16

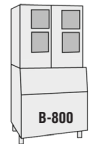

B-800

48 x 32 1/2 x 76 5/16

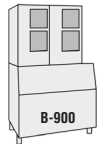

B-900

52 x 32 1/2 x 76 5/16

Dimensions shown in W x D x H include Bins. See TOP KIT MATRIX (pg 35) for top kit options based on bin size.

KM-901M_J





KMEdge Cubers

Dimensions: 30"W X 27 ^{3/8}"D X 32 ^{1/2}"H
(ice machine dimensions only)



Model Number	Condenser	Lbs. of Ice per 24 hours 90°A / 70°W	Lbs. of Ice per 24 hours 70°A / 50°W	Electrical	kWh per 100 Lbs.	Shipping Weight	List F.O.B. Griffin
KM-901MAJ	Air-Cooled	753	905	208-230V/60/1	5.0	260 Lbs.	\$8,470
KM-901MWJ	Water-Cooled	864	928	208-230V/60/1	4.5	249 Lbs.	\$8,470
KM-901MRJ	Remote A-C	853	904	208-230V/60/1	4.5	250 Lbs.	\$8,370
KM-901MRJ3	Remote A-C	815	899	208-230/60/3	5.4	258 Lbs.	\$8,470
Model Number	Condenser	Kgs. of Ice per 24 hours 32°A / 21°W	Kgs. of Ice per 24 hours 21°A / 10°W	Electrical	kWh per 45 Kgs.	Shipping Weight	List F.O.B. Griffin
KM-901MAH50	Air-Cooled	320	398	208-230V/50/1	5.1	116 Kg.	\$8,770

Accessories: H9320-52 Recommended Water Filtration - Twin Configuration \$606
 HS-5245 Tamper Proof Kit - Air Cooled Units \$470
 HS-5246 Tamper Proof Kit - Water Cooled Units \$470

Use URC-14F Condenser for Remote Air-Cooled Unit

"50" suffix designates 50 hertz models

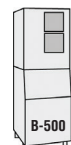

B-500

30 x 32 1/2 x 78 1/2

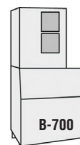

B-700

44 x 32 1/2 x 78 1/2

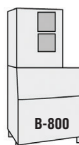

B-800

48 x 32 1/2 x 78 1/2

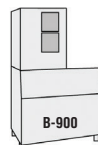

B-900

52 x 32 1/2 x 78 1/2

Dimensions shown in W x D x H include Bins. See TOP KIT MATRIX (pg 35) for top kit options based on bin size.



CUBER

KM-1100M_J





KMEdge Cubers

Dimensions: 30"W X 27 3/8"D X 32 1/2"H
(ice machine dimensions only)







Model Number	Condenser	Lbs. of Ice per 24 hours 90°A / 70°W	Lbs. of Ice per 24 hours 70°A / 50°W	Electrical	kWh per 100 Lbs.	Shipping Weight	List F.O.B. Griffin
KM-1100MAJ	Air-Cooled	935	1087	208-230V/60/1	4.9	290 Lbs.	\$9,800
KM-1100MWH	Water-Cooled	1076	1111	208-230V/60/1	3.81	285 Lbs.	\$9,800
KM-1100MRJ	Remote A-C	1030	1156	208-230V/60/1	4.5	272 Lbs.	\$9,700

Accessories: H9320-52 Recommended Water Filtration - Twin Configuration \$606

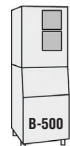
Use URC-14F Condenser for Remote Air-Cooled Unit

30 x 32 1/2 x 78 1/2 44 x 32 1/2 x 78 1/2 48 x 32 1/2 x 78 1/2 52 x 32 1/2 x 78 1/2

Dimensions shown in W x D x H include Bins. See TOP KIT MATRIX (pg 35) for top kit options based on bin size.

KM-1301S_J



KMEdge Cubers





Dimensions: 48"W X 27 3/8"D X 27 3/8"H
(ice machine dimensions only)



Model Number	Condenser	Lbs. of Ice per 24 hours 90°A / 70°W	Lbs. of Ice per 24 hours 70°A / 50°W	Electrical	kWh per 100 Lbs.	Shipping Weight	List F.O.B. Griffin
KM-1301SAJ	Air-Cooled	1301	1365	208-230V/60/1	4.27	338 Lbs.	\$10,830
KM-1301SWJ	Water-Cooled	1230	1247	208-230V/60/1	3.76	335 Lbs.	\$10,830
KM-1301SRJ	Remote A-C	1260	1400	208-230V/60/1	4.28	339 Lbs.	\$10,710
KM-1301SAJ3*	Air-Cooled	1350	1427	208-230V/60/3	3.95	338 Lbs.	\$10,940
KM-1301SWJ3	Water-Cooled	1355	1360	208-230V/60/3	3.25	335 Lbs.	\$10,940
KM-1301SRJ3*	Remote A-C	1330	1433	208-230V/60/3	3.83	339 Lbs.	\$10,830

Model Number	Condenser	Kgs. of Ice per 24 hours 32°A / 21°W	Kgs. of Ice per 24 hours 21°A / 10°W	Electrical	kWh per 45 Kgs.	Shipping Weight	List F.O.B. Griffin
KM-1301SAH-E	Remote A-C	455	505	220-240/50/1*	4.3	143 Kgs.	\$11,390





Accessories: H9320-53 Recommended Water Filtration - Triple Configuration \$845
 HS-5252 Tamper Proof Kit - Air Cooled Units \$520
 HS-5253 Tamper Proof Kit - Water Cooled Units \$520

Use URC-14F Condenser for Remote Air-Cooled Unit

"E" suffix designates 50 hertz models

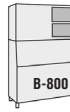
***ENERGY STAR qualified**

48 x 32 1/2 x 73 3/8 48 x 32 1/2 x 101 3/4 52 x 32 1/2 x 73 3/8 52 x 32 1/2 x 101 3/4

Dimensions shown in W x D x H include Bins. See TOP KIT MATRIX (pg 35) for top kit options based on bin size.

CUBER



KM-1340M_H



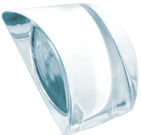



KM Cubers

Dimensions: 30"W X 27^{3/8}"D X 41^{1/2}"H
(ice machine dimensions only)

Model Number	Condenser	Lbs. of Ice per 24 hours 90°A / 70°W	Lbs. of Ice per 24 hours 70°A / 50°W	Electrical	kWh per 100 Lbs.	Shipping Weight	List F.O.B. Griffin
KM-1340MAH	Air-Cooled	1167	1325	208-230V/60/1**	4.7	315 Lbs.	\$11,150
KM-1340MWH	Water-Cooled	1316	1329	208-230V/60/1**	3.9	293 Lbs.	\$11,150
KM-1340MRH	Remote A-C	1251	1401	208-230V/60/1**	4.5	289 Lbs.	\$11,050
KM-1340MRH3	Remote A-C	1185	1364	208-230V/60/3*	4.75	289 Lbs.	\$11,150

Accessories: **HS-5030 Transformer Kit - 4 wire to 3 wire (eliminates need for dedicated neutral) \$160
H9320-52 Recommended Water Filtration - Twin Configuration \$606

30 x 32 1/2 x 87 1/2

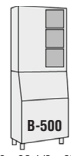

44 x 32 1/2 x 87 1/2



48 x 32 1/2 x 87 1/2

52 x 32 1/2 x 87 1/2

Use URC-14F Condenser for Remote Air-Cooled Unit
Dimensions shown in W x D x H include Bins. See TOP KIT MATRIX (pg 35) for top kit options based on bin size.

KM-1601MRJ









KM Cubers

Dimensions: 30"W X 27^{3/8}"D X 41^{11/16}"H
(ice machine dimensions only)

Model Number	Condenser	Lbs. of Ice per 24 hours 90°A / 70°W	Lbs. of Ice per 24 hours 70°A / 50°W	Electrical	kWh per 100 Lbs.	Shipping Weight	List F.O.B. Griffin
KM-1601MRJ	Remote A-C	1550	1594	208-230V/60/1**	4.35	316 Lbs.	\$13,150
KM-1601MRJ3	Remote A-C	1550	1653	208-230V/60/3	4.09	316 Lbs.	\$13,260

Accessories: **HS-5030 Transformer Kit - 4 wire to 3 wire (eliminates need for dedicated neutral) \$160
H9320-52 Recommended Water Filtration - Twin Configuration \$606

30 x 32 1/2 x 87 1/2

44 x 32 1/2 x 87 1/2

48 x 32 1/2 x 87 1/2



52 x 32 1/2 x 87 1/2

Use URC-22F Condenser for Remote Air-Cooled Unit
Dimensions shown in W x D x H include Bins. See TOP KIT MATRIX (pg 35) for top kit options based on bin size.



CUBER

KM-1601S_J









KMEdge Cubers

Dimensions: 48"W X 27 3/8"D X 27 3/8"H
(ice machine dimensions only)





Model Number	Condenser	Lbs. of Ice per 24 hours 90°A / 70°W	Lbs. of Ice per 24 hours 70°A / 50°W	Electrical	kWh per 100 Lbs.	Shipping Weight	List F.O.B. Griffin
KM-1601SAJ	Air-Cooled	1433	1513	208-230V/60/1**	4.24	315 Lbs.	\$12,880
KM-1601SWJ	Water-Cooled	1650	1660	208-230V/60/1**	3.30	360 Lbs.	\$12,880
KM-1601SRJ*	Remote A-C	1600	1640	208-230V/60/1**	3.96	350 Lbs.	\$12,770
KM-1601SAJ3	Air-Cooled	1414	1513	208-230V/60/3	4.40	315 Lbs.	\$12,980
KM-1601SWJ3	Water-Cooled	1660	1671	208-230V/60/3	3.32	360 Lbs.	\$13,100
KM-1601SRJ3	Remote A-C	1600	1635	208-230V/60/3	4.14	350 Lbs.	\$12,980

Accessories: **HS-5030 Transformer Kit - 4 wire to 3 wire (eliminates need for dedicated neutral) \$160
H9320-52 Recommended Water Filtration - Twin Configuration \$606

Use URC-22F Condenser for Remote Air-Cooled Unit

*ENERGY STAR qualified







48 x 32 1/2 x 73 3/8 48 x 32 1/2 x 101 3/4 52 x 32 1/2 x 73 3/8 52 x 32 1/2 x 101 3/4

Dimensions shown in W x D x H include Bins. See TOP KIT MATRIX (pg 35) for top kit options based on bin size.

KM-1900S_J









KMEdge Cubers

Dimensions: 48"W X 27 3/8"D X 36 7/16"H
(ice machine dimensions only)





Model Number	Condenser	Lbs. of Ice per 24 hours 90°A / 70°W	Lbs. of Ice per 24 hours 70°A / 50°W	Electrical	kWh per 100 Lbs.	Shipping Weight	List F.O.B. Griffin
KM-1900SAJ*	Air-Cooled	1675	1875	208-230V/60/1**	3.9	415 Lbs.	\$13,740
KM-1900SWJ	Water-Cooled	1875	1880	208-230V/60/1**	3.2	415 Lbs.	\$13,740
KM-1900SRJ*	Remote A-C	1700	1933	208-230V/60/1**	3.9	415 Lbs.	\$13,630
KM-1900SAJ3*	Air-Cooled	1675	1865	208-230V/60/3	3.9	415 Lbs.	\$13,910
KM-1900SWJ3	Water-Cooled	1875	1880	208-230V/60/3	3.2	415 Lbs.	\$13,910
KM-1900SRJ3	Remote A-C	1700	1933	208-230V/60/3	3.9	415 Lbs.	\$13,850

Accessories: **HS-5030 Transformer Kit - 4 wire to 3 wire (eliminates need for dedicated neutral) \$160
H9320-52 Recommended Water Filtration - Twin Configuration \$606
HS-5254 Tamper Proof Kit - Air Cooled Units \$580
HS-5255 Tamper Proof Kit - Water Cooled Units \$580

Use URC-22F Condenser for Remote Air-Cooled Unit

*ENERGY STAR qualified

48 x 32 1/2 x 82 7/16 48 x 32 1/2 x 119 7/8 52 x 32 1/2 x 82 7/16 52 x 32 1/2 x 119 7/8

Dimensions shown in W x D x H include Bins. See TOP KIT MATRIX (pg 35) for top kit options based on bin size.

CUBER



KM-2200S_J3







KMEdge Cubers

Dimensions: 48"W X 27 ³/₈"D X 36 ⁷/₁₆"H
(ice machine dimensions only)







Model Number	Condenser	Lbs. of Ice per 24 hours 90°A / 70°W	Lbs. of Ice per 24 hours 70°A / 50°W	Electrical	kWh per 100 Lbs.	Shipping Weight	List F.O.B. Griffin
KM-2200SWJ3	Water-Cooled	2200	2221	208-230V/60/3	3.11	440 Lbs.	\$17,300
KM-2200SRJ3*	Remote A-C	2075	2206	208-230V/60/3	3.75	440 Lbs.	\$17,200

Accessories: H9320-52 Recommended Water Filtration - Twin Configuration \$606

Use URC-22F Condenser for Remote Air-Cooled Unit

***ENERGY STAR qualified**

48 x 32 1/2 x 82 7/16 48 x 32 1/2 x 119 7/8 52 x 32 1/2 x 82 7/16 52 x 32 1/2 x 119 7/8

Dimensions shown in W x D x H include Bins. See TOP KIT MATRIX (pg 35) for top kit options based on bin size.

KM-2600S_J3







KMEdge Cubers

Dimensions: 48"W X 27 ³/₈"D X 36 ⁷/₁₆"H
(ice machine dimensions only)







Model Number	Condenser	Lbs. of Ice per 24 hours 90°A / 70°W	Lbs. of Ice per 24 hours 70°A / 50°W	Electrical	kWh per 100 Lbs.	Shipping Weight	List F.O.B. Griffin
KM-2600SWJ3	Water-Cooled	2480	2482	208-230V/60/3	3.6	440 Lbs.	\$18,940
KM-2600SRJ3*	Remote A-C	2580	2617	208-230V/60/3	3.61	440 Lbs.	\$18,180

Accessories: H9320-53 Recommended Water Filtration - Triple Configuration \$845

Use URC-26J Condenser for Remote Air-Cooled Unit

***ENERGY STAR qualified**

48 x 32 1/2 x 82 7/16 48 x 32 1/2 x 119 7/8 52 x 32 1/2 x 82 7/16 52 x 32 1/2 x 119 7/8

Dimensions shown in W x D x H include Bins. See TOP KIT MATRIX (pg 35) for top kit options based on bin size.



CUBER Dispenser

KMD-410M_H



KM Cubers

Dimensions: 22"W X 24"D X 24"H
(ice machine dimensions only)



Model Number	Condenser	Lbs. of Ice per 24 hours 90°A / 70°W	Lbs. of Ice per 24 hours 70°A / 50°W	Electrical	kWh per 100 Lbs.	Shipping Weight	List F.O.B. Griffin
KMD-410MAH	Air-Cooled	324	415	115-120V/60/1	5.8	161 Lbs.	\$5,230
KMD-410MWH	Water-Cooled	382	440	115-120V/60/1	4.3	163 Lbs.	\$5,230

Accessories: H9320-51 Recommended Water Filtration - Single Configuration

\$355



22 x 30 1/2 x 35 3/8



22 x 32 1/2 x 68 1/8

Dimensions shown in W x D x H include Bins. See TOP KIT MATRIX (pg 35) for top kit options based on bin size.

KMD-460M_H



KM Cubers

Dimensions: 30"W X 24 1/4"D X 22 1/8"H
(ice machine dimensions only)



Model Number	Condenser	Lbs. of Ice per 24 hours 90°A / 70°W	Lbs. of Ice per 24 hours 70°A / 50°W	Electrical	kWh per 100 Lbs.	Shipping Weight	List F.O.B. Griffin
KMD-460MAH	Air-Cooled	387	457	115-120V/60/1	5.5	170 Lbs.	\$5,580
KMD-460MWH	Water-Cooled	470	505	115-120V/60/1	4.1	170 Lbs.	\$5,580

Accessories: H9320-51 Recommended Water Filtration - Single Configuration

\$355

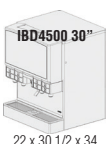

22 x 30 1/2 x 34



30 x 32 1/2 x 68 1/8

Dimensions shown in W x D x H include Bins. See TOP KIT MATRIX (pg 35) for top kit options based on bin size.

KMD-530M_H



KM Edge Cubers

Dimensions: 30"W X 24 1/4"D X 22 1/8"H
(ice machine dimensions only)



Model Number	Condenser	Lbs. of Ice per 24 hours 90°A / 70°W	Lbs. of Ice per 24 hours 70°A / 50°W	Electrical	kWh per 100 Lbs.	Shipping Weight	List F.O.B. Griffin
KMD-530MAH	Air-Cooled	462	553	115-120V/60/1	5.7	170 Lbs.	\$5,790
KMD-530MWH	Water-Cooled	520	540	115-120V/60/1	4.4	170 Lbs.	\$5,790
KMD-530MRH	Remote A-C	488	560	115-120V/60/1	5.8	170 Lbs.	\$5,680

Accessories: H9320-51 Recommended Water Filtration - Single Configuration

\$355



22 x 30 1/2 x 34



30 x 32 1/2 x 68 1/8

Use URC-5F Condenser for Remote Air-Cooled Unit

Dimensions shown in W x D x H include Bins. See TOP KIT MATRIX (pg 35) for top kit options based on bin size.

CUBER Dispenser



KMD-850MAH









KM Cuber

Dimensions: 30"W X 24^{5/8}"D X 28"H
(ice machine dimensions only)

Model Number	Condenser	Lbs. of Ice per 24 hours 90°A / 70°W	Lbs. of Ice per 24 hours 70°A / 50°W	Electrical	kWh per 100 Lbs.	Shipping Weight	List F.O.B. Griffin
KMD-850MAH	Air-Cooled	625	772	208-230V/60/1	6.2	249 Lbs.	\$7,330

Accessories: H9320-52 Recommended Water Filtration - Twin Configuration \$606







Lancer FS30
30 x 30 1/2 x 39 5/8



B-500
30 x 32 1/2 x 68 1/8



B-800
48 x 32 1/2 x 74

Dimensions shown in W x D x H include Bins. See TOP KIT MATRIX (pg 35) for top kit options based on bin size.

KMD-901M_H









KM Cubers

Dimensions: 30"W X 24^{5/8}"D X 28"H
(ice machine dimensions only)

Model Number	Condenser	Lbs. of Ice per 24 hours 90°A / 70°W	Lbs. of Ice per 24 hours 70°A / 50°W	Electrical	kWh per 100 Lbs.	Shipping Weight	List F.O.B. Griffin
KMD-901MWH	Water-Cooled	860	922	208-230V/60/1***	4.3	251 Lbs.	\$8,830
KMD-901MRH	Remote A-C	775	848	208-230V/60/1**	5.3	258 Lbs.	\$8,280

Accessories: **HS-5030 Transformer Kit - 4 wire to 3 wire (eliminates need for dedicated neutral) \$160
H9320-52 Recommended Water Filtration - Twin Configuration \$606



Lancer-FS30
30 x 30 1/2 x 39 5/8



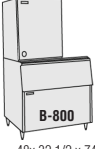

B-800
48x 32 1/2 x 74

Dimensions shown in W x D x H include Bins. See TOP KIT MATRIX (pg 35) for top kit options based on bin size.

Use URC-9F Condenser for Remote Air-Cooled Unit

KMH-2000S_H









KM Cubers

Dimensions: 36"W X 40"D X 36^{7/16}"H
(ice machine dimensions only)

Model Number	Condenser	Lbs. of Ice per 24 hours 90°A / 70°W	Lbs. of Ice per 24 hours 70°A / 50°W	Electrical	kWh per 100 Lbs.	Shipping Weight	List F.O.B. Griffin
KMH-2000SWH3	Water-Cooled	1840	1843	208-230V/60/3	3.19	415 Lbs.	\$16,160
KMH-2000SRH*	Remote A-C	1694	1944	208-230V/60/1***	3.80	415 Lbs.	\$15,950
KMH-2000SRH3*	Remote A-C	1675	1929	208-230V/60/3	3.70	415 Lbs.	\$16,060

Accessories: **HS-5030 Transformer Kit - 4 wire to 3 wire (eliminates need for dedicated neutral) \$160
H9320-52 Recommended Water Filtration - Twin Configuration \$606



Use URC-22F Condenser for Remote Air-Cooled Unit

*ENERGY STAR qualified



CUBER Low Profile

KML-325M_J

Low Profile KMEdge Cubers

Dimensions: 30"W X 27^{3/8}"D X 22"H
(ice machine dimensions only)

Model Number	Condenser	Lbs. of Ice per 24 hours 90°A / 70°W	Lbs. of Ice per 24 hours 70°A / 50°W	Electrical	kWh per 100 Lbs.	Shipping Weight	List F.O.B. Griffin
KML-325MAJ	Air-Cooled	300	380	115V/60/1	5.72	185 Lbs.	\$4,650
KML-325MWJ	Water-Cooled	355	385	115V/60/1	4.51	185 Lbs.	\$4,650

Accessories: H9320-51 Recommended Water Filtration - Single Configuration \$355

Use URC-9F Condenser for Remote Air-Cooled Unit

30 x 32 1/2 x 55 3/8 30 x 32 1/2 x 68 30 x 30 x 75

Dimensions shown in W x D x H include Bins. See TOP KIT MATRIX (pg 35) for top kit options based on bin size.

KML-500M_J

Low Profile KMEdge Cubers

Dimensions: 30"W X 27^{3/8}"D X 22"H
(ice machine dimensions only)

Model Number	Condenser	Lbs. of Ice per 24 hours 90°A / 70°W	Lbs. of Ice per 24 hours 70°A / 50°W	Electrical	kWh per 100 Lbs.	Shipping Weight	List F.O.B. Griffin
KML-500MAJ	Air-Cooled	400	442	115V/60/1	5.55	185 Lbs.	\$5,300
KML-500MWJ	Water-Cooled	515	543	115V/60/1	4.33	185 Lbs.	\$5,300

Accessories: H9320-51 Recommended Water Filtration - Single Configuration \$355

Use URC-9F Condenser for Remote Air-Cooled Unit

30 x 32 1/2 x 55 3/8 30 x 32 1/2 x 68 30 x 30 x 75

Dimensions shown in W x D x H include Bins. See TOP KIT MATRIX (pg 35) for top kit options based on bin size.

KML-700M_J

Low Profile KMEdge Cubers

Dimensions: 30"W X 27^{3/8}"D X 26"H
(ice machine dimensions only)

Model Number	Condenser	Lbs. of Ice per 24 hours 90°A / 70°W	Lbs. of Ice per 24 hours 70°A / 50°W	Electrical	kWh per 100 Lbs.	Shipping Weight	List F.O.B. Griffin
KML-700MAJ	Air-Cooled	572	658	115V/60/1	5.16	220 Lbs.	\$6,500
KML-700MWJ	Water-Cooled	730	756	115V/60/1	3.61	220 Lbs.	\$6,500
KML-700MRJ*	Remote A-C	643	742	115V/60/1	4.70	220 Lbs.	\$6,400

Accessories: H9320-51 Recommended Water Filtration - Single Configuration \$355

Use URC-9F Condenser for Remote Air-Cooled Unit

*ENERGY STAR qualified

30 x 32 1/2 x 59 3/8 30 x 32 1/2 x 72 30 x 30 x 79

Dimensions shown in W x D x H include Bins. See TOP KIT MATRIX (pg 35) for top kit options based on bin size.

CUBER Serenity



KMS-822MLH







KM Cuber

Dimensions: 22"W X 24^{5/8}"D X 28"H
(ice machine dimensions only)

Model Number	Condenser	Lbs. of Ice per 24 hours 90°A / 70°W	Lbs. of Ice per 24 hours 70°A / 50°W	Electrical	kWh per 100 Lbs.	Shipping Weight	List F.O.B. Griffin
KMS-822MLH using 1 Phase Remote Condenser†	Remote A-C	774	839	115V/60/1*	5.58	152 Lbs.	\$7,360

Accessories: **HS-5062** Extension bracket for freestyle application \$138
H9320-52 Recommended Water Filtration - Twin Configuration \$606



IBD 4500 22"
22 x 30 1/2 x 35 3/8

Designed for use on Beverage Dispensers
 Use SRK-10H Condenser for Remote Air-Cooled Unit (sold separately)
 *115V supply for the KMS Ice maker is supplied from the SRK remote condenser

Dimensions shown in W x D x H include Bins.
 See TOP KIT MATRIX (pg 35) for top kit options based on bin size.

KMS-830MLH







KM Cuber

Dimensions: 30"W X 16^{1/2}"D X 29"H
(ice machine dimensions only)

Model Number	Condenser	Lbs. of Ice per 24 hours 90°A / 70°W	Lbs. of Ice per 24 hours 70°A / 50°W	Electrical	kWh per 100 Lbs.	Shipping Weight	List F.O.B. Griffin
KMS-830MLH using 1 Phase Remote Condenser†	Remote A-C	700	820	115V/60/1*	5.50	137 Lbs.	\$7,760

Accessories: **H9320-51** Recommended Water Filtration - Single Configuration \$355



Lancer FS30
30 x 30 1/2 x 39 5/8

Designed for use on Beverage Dispensers
 †Use SRK-8H Condenser for Remote Air-Cooled Unit (sold separately)
 *115V supply for the KMS Ice maker is supplied from the SRK remote condenser

Dimensions shown in W x D x H include Bins.
 See TOP KIT MATRIX (pg 35) for top kit options based on bin size.

KMS-1122MLH







KM Cuber

Dimensions: 22"W X 18"D X 31^{1/4}"H
(ice machine dimensions only)

Model Number	Condenser	Lbs. of Ice per 24 hours 90°A / 70°W	Lbs. of Ice per 24 hours 70°A / 50°W	Electrical	kWh per 100 Lbs.	Shipping Weight	List F.O.B. Griffin
KMS-1122MLH using 1 Phase Remote Condenser†	Remote A-C	985	1100	115V/60/1*	4.65	150 Lbs.	\$8,280
KMS-1122MLH using 3 Phase Remote Condenser†	Remote A-C	1000	1120	115V/60/3*	4.6	150 Lbs.	\$8,280

Accessories: **H9320-52** Recommended Water Filtration - Twin Configuration \$606



Lancer FS22
22 x 30 1/2 x 40 1/4

Designed for use on Beverage Dispensers
 †Use SRK-12H or SRK-12H3 Condenser for Remote Air-Cooled Unit (sold separately)
 *115V supply for the KMS Ice maker is supplied from the SRK remote condenser

Dimensions shown in W x D x H include Bins.
 See TOP KIT MATRIX (pg 35) for top kit options based on bin size.



CUBER Serenity



KMS-1401MLJ



KM Cubers

Dimensions: 30"W X 24"D X 28"H
(ice machine dimensions only)



Model Number	Condenser	Lbs. of Ice per 24 hours 90°A / 70°W	Lbs. of Ice per 24 hours 70°A / 50°W	Electrical	kWh per 100 Lbs.	Shipping Weight	List F.O.B. Griffin
KMS-1401MLJ using 1 Phase Remote Condenser†	Remote A-C	1280	1420	115V/60/1*	4.70	177 Lbs.	\$8,300
KMS-1401MLJ using 3 Phase Remote Condenser†	Remote A-C	1280	1400	115V/60/3*	4.70	177 Lbs.	\$8,300

Accessories: **H9320-52** Recommended Water Filtration - Twin Configuration

\$606



†Use SRK-14J or SRK-14J3 Condenser for Remote Air-Cooled Unit (sold separately)

*115V supply for the KMS Ice maker is supplied from the SRK remote condenser

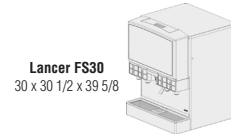

Lancer FS30
30 x 30 1/2 x 39 5/8

Dimensions shown in W x D x H include Bins.
See TOP KIT MATRIX (pg 35) for top kit options based on bin size.

KMS-2000MLH

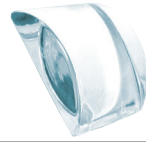

KM Cubers

Dimensions: 30"W X 24"D X 32 7/8"H
(ice machine dimensions only)



Model Number	Condenser	Lbs. of Ice per 24 hours 90°A / 70°W	Lbs. of Ice per 24 hours 70°A / 50°W	Electrical	kWh per 100 Lbs.	Shipping Weight	List F.O.B. Griffin
KMS-2000MLH using 1 Phase Remote Condenser†	Remote A-C	1786	1861	115V/60/1*	4.70	206 Lbs.	\$10,270
KMS-2000MLH using 3 Phase Remote Condenser†	Remote A-C	1706	1910	115V/60/3*	4.65	206 Lbs.	\$10,270

Accessories: **H9320-53** Recommended Water Filtration - Triple Configuration

\$845



††Use SRK-20H or SRK-20H3 Condenser for Remote Air-Cooled Unit (sold separately)

*115V supply for the KMS Ice maker is supplied from the SRK remote condenser

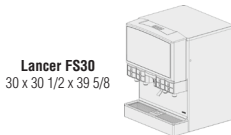

Lancer FS30
30 x 30 1/2 x 39 5/8

Dimensions shown in W x D x H include Bins.
See TOP KIT MATRIX (pg 35) for top kit options based on bin size.



Features & Benefits of the IM Square Cuber

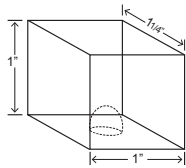
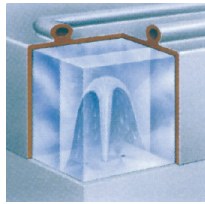

- **HOSHIZAKI IM Square Cubers** utilize an ice making system that has an automatic rinse cycle, which means each ice cycle is made with fresh water protecting the integrity and flavor of the drink.
- A closed water circuit offers the ultimate contamination protection, by reducing the number of points at which impurities can enter the ice making process.
- A stainless steel exterior with integrated door handles provides a hygienic and high quality finish (Self contained unit only)
- Removable door gaskets prevent any heat and contamination from entering the bin making the product easy to clean and maintain. (Self contained unit only)
- Easily cleanable air filter extends the life of the ice machine
- **HOSHIZAKI IM Square Cubers** are electronically controlled for consistent quality of ice
- Natural foaming agent insulates and preserves the quality and consistency of the ice produced longer than any other machine available - saving energy and money

IM-200BAA		IM Square Cuber with Built-In Bin						
		Dimensions: 39 1/2"W X 23 5/8"D X 33 1/2"H (including 6" legs)						
		Model Number	Condenser	Lbs. of Ice per 24 hours 90°A / 70°W	Lbs. of Ice per 24 hours 70°A / 50°W	Electrical	kWh per 100 Lbs.	Shipping Weight
IM-200BAA		Air-Cooled	160	200	115V/60/1	8.3	203 lbs.	\$6,000
		Accessories: H9320-51 Recommended Water Filtration - Single Configuration						\$355
		*Rated in accordance with AHRI Standard 820(I-P). Capacity based on 100% of total volume x 30 lb/ft ³ average density of ice.						

IM-500SAA		IM Square Cuber						
		Dimensions: 44"W X 27 5/8"D X 21 3/4"H (ice machine dimensions only)						
		Model Number	Condenser	Lbs. of Ice per 24 hours 90°A / 70°W	Lbs. of Ice per 24 hours 70°A / 50°W	Electrical	kWh per 100 Lbs.	Shipping Weight
IM-500SAA*		Air-Cooled	435	500	115V/60/1	5.45	220 Lbs.	\$7,500
		Accessories: S-25691 Stacking Kit (Order as Accessory)						\$510
		H9320-51 Recommended Water Filtration - Single Configuration						\$355
*ENERGY STAR qualified		44 x 32 1/2 x 67 3/4		44 x 32 1/2 x 89 1/2		48 x 32 1/2 x 67 3/4		
		48 x 32 1/2 x 89 1/2		52 x 32 1/2 x 67 3/4		52 x 32 1/2 x 89 1/2		
		Dimensions shown in W x D x H include Bins. See TOP KIT MATRIX (pg 35) for top kit options based on bin size.						



FLAKER Self Contained

Features & Benefits of the Flaker / Cubelet Series



- Attractive stainless steel exterior
- Most models are available in both flaked and cubelet style ice
- The internal auger design produces the highest quality ice with fewer repairs and less down time
- The freezing cylinder is made from cast stainless steel
- The industry's only greaseless bearing design improves life of the machine
- **HOSHIZAKI Flaker and Cubelet** ice machines have electric water inlet valves and an automatic purge of water from the reservoir for cleaner operation and longer bearing life
- Features Advanced CleanCycle24™ design - 2 second rinse every hour
- Self-contained flakers flush automatically when bin control is activated

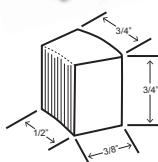

FLAKED ICE USAGE GUIDE

Establishment	Approximate Daily Usage
Restaurant	1.5 lbs. ice per seat
Salad Bar/Seafood Display	30 lbs. ice per ft3
Hospital	
Patient Care	10 lbs. ice per bed
Cafeteria	1 lb. ice per seat
Nursing Home	6 lbs. per bed

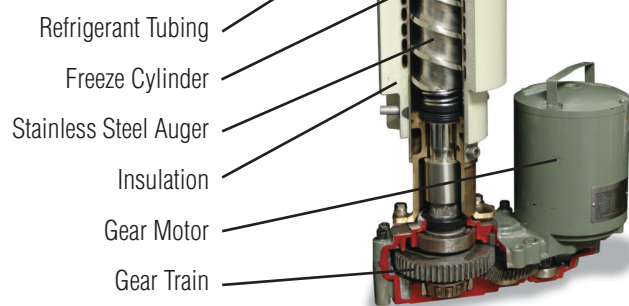

F-300BAJ		Undercounter FLAKER with Built-In Bin						
		Dimensions: 36"W X 24 1/4"D X 39 1/4"H (*6" Legs Included)					Self-Contained Bin Storage Capacity Up to 110 Lbs. †	
	Model Number	Condenser	Lbs. of Ice per 24 hours 90° A / 70° W	Lbs. of Ice per 24 hours 70° A / 50° W	Electrical	kWh per 100 Lbs.	Shipping Weight	List F.O.B. Griffin
	F-300BAJ	Air-Cooled	247	353	115V/60/1	6.14	221 Lbs.	\$7,790
Accessories								
LP-6 LEG Four 6" Stainless Steel Legs Package available (optional)								\$212
H9320-51 Recommended Water Filtration - Single Configuration								\$355
Four 6" Legs Package (LP-6P LEG) included								
†Rated in accordance with AHRI Standard 820(I-P). Capacity based on 100% of total volume x 30 lb/ft³ average density of ice.								

F-330BAJ		Undercounter FLAKER with Built-In Bin						
		Dimensions: 24"W X 26"D X 39"H (*6" Legs Included)					Self-Contained Bin Storage Capacity Up to 80 Lbs. †	
	Model Number	Condenser	Lbs. of Ice per 24 hours 90° A / 70° W	Lbs. of Ice per 24 hours 70° A / 50° W	Electrical	kWh per 100 Lbs.	Shipping Weight	List F.O.B. Griffin
	F-330BAJ	Air-Cooled	243	332	115V/60/1	5.91	178 Lbs.	\$7,150
Accessories								
LP-6 LEG Four 6" Stainless Steel Legs Package available (optional)								\$212
H9320-51 Recommended Water Filtration - Single Configuration								\$355
Four 6" Legs Package (LP-6P LEG) included								
†Rated in accordance with AHRI Standard 820(I-P). Capacity based on 100% of total volume x 30 lb/ft³ average density of ice.								



FLAKER

F-500BAJ

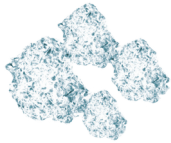

Undercounter **FLAKER** with Built-In Bin

Dimensions: 38"W X 29"D X 42"H
(*6" Legs Included)

Self-Contained Bin Storage
Capacity Up to 170 Lbs.†

Model Number	Condenser	Lbs. of Ice per 24 hours 90°A / 70°W	Lbs. of Ice per 24 hours 70°A / 50°W	Electrical	kWh per 100 Lbs.	Shipping Weight	List F.O.B. Griffin
F-500BAJ	Air-Cooled	420	536	115V/60/1	5.05	270 Lbs.	\$9,050

Accessories

LP-6 LEG Four 6" Stainless Steel Legs Package available (optional) \$212

H9320-51 Recommended Water Filtration - Single Configuration \$355



Four 6" Legs Package (LP-6P LEG) included

†Rated in accordance with AHRI Standard 820(I-P). Capacity based on 100% of total volume x 30 lb/ft³ average density of ice.

F-450MAJ

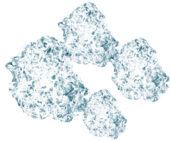

FLAKER

Dimensions: 22"W X 27^{3/8}"D X 22"H
(ice machine dimensions only)

Model Number	Condenser	Lbs. of Ice per 24 hours 90°A / 70°W	Lbs. of Ice per 24 hours 70°A / 50°W	Electrical	kWh per 100 Lbs.	Shipping Weight	List F.O.B. Griffin
F-450MAJ*	Air-Cooled	395	492	115V/60/1	4.94	170 Lbs.	\$6,670

Accessories

H9320-51 Recommended Water Filtration - Single Configuration \$355



*Not recommended for dispensing applications

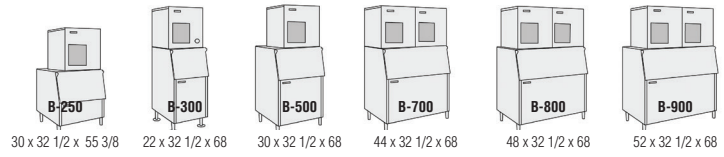

Dimensions shown in W x D x H include Bins. See TOP KIT MATRIX (pg 35) for top kit options based on bin size.

F-801M_J

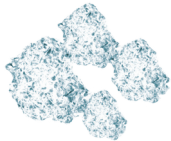

FLAKERS

Dimensions: 22"W X 27^{3/8}"D X 26"H
(ice machine dimensions only)

Model Number	Condenser	Lbs. of Ice per 24 hours 90°A / 70°W	Lbs. of Ice per 24 hours 70°A / 50°W	Electrical	kWh per 100 Lbs.	Shipping Weight	List F.O.B. Griffin
F-801MAJ*	Air-Cooled	566	751	115V/60/1	4.5	205 Lbs.	\$8,390
F-801MWJ	Water-Cooled	605	680	115V/60/1	3.9	205 Lbs.	\$8,560

Accessories

HS-2120 Cutter head for finer flaked ice \$180

H9320-51 Recommended Water Filtration - Single Configuration \$355



*ENERGY STAR qualified

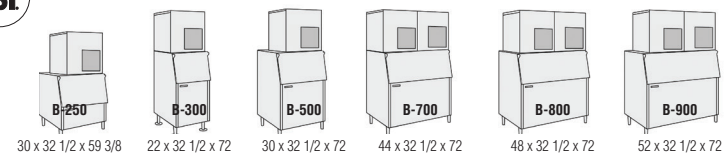

Dimensions shown in W x D x H include Bins. See TOP KIT MATRIX (pg 35) for top kit options based on bin size.









F-1002M_J

Model Number		Condenser	Lbs. of Ice per 24 hours 90°A / 70°W	Lbs. of Ice per 24 hours 70°A / 50°W	Electrical	kWh per 100 Lbs.	Shipping Weight	List F.O.B. Griffin
F-1002MAJ		Air-Cooled	758	980	115V/60/1	4.36	210 Lbs.	\$10,390
F-1002MWJ		Water-Cooled	833	955	115V/60/1	3.57	205 Lbs.	\$10,390
F-1002MRJ		Remote A-C	722	907	115V/60/1	4.1	210 Lbs.	\$10,290
F-1002MLJ		N/A	797	1028	115V/60/1	1.51	205 Lbs.	\$9,170

Accessories
HS-2120 Cutter head for finer flaked ice \$180
H9320-51 Recommended Water Filtration - Single Configuration \$355

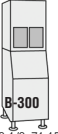
Use URC-5F Condenser for Remote Air-Cooled Unit

22 x 32 1/2 x 71 15/16 30 x 32 1/2 x 71 15/16 44 x 32 1/2 x 71 15/16 48 x 32 1/2 x 71 15/16 52 x 32 1/2 x 71 15/16
 Dimensions shown in W x D x H include Bins. See TOP KIT MATRIX (pg 35) for top kit options based on bin size.









F-1501M_J

Model Number		Condenser	Lbs. of Ice per 24 hours 90°A / 70°W	Lbs. of Ice per 24 hours 70°A / 50°W	Electrical	kWh per 100 Lbs.	Shipping Weight	List F.O.B. Griffin
F-1501MAJ		Air-Cooled	1154	1543	208-230V/60/1**	4.0	325 Lbs.	\$13,170
F-1501MWJ		Water-Cooled	1410	1624	208-230V/60/1**	3.20	325 Lbs.	\$13,200
F-1501MRJ		Remote A-C	1370	1705	208-230V/60/1**	3.44	325 Lbs.	\$13,070

Accessories
H9320-51 Recommended Water Filtration - Single Configuration \$355

Use URC-14F Condenser for Remote Air-Cooled Unit

30 x 32 1/2 x 79 1/4 44 x 32 1/2 x 79 1/4 48 x 32 1/2 x 79 1/4 52 x 32 1/2 x 79 1/4
 Dimensions shown in W x D x H include Bins. See TOP KIT MATRIX (pg 35) for top kit options based on bin size.









F-2001M

Model Number		Condenser	Lbs. of Ice per 24 hours 90°A / 70°W	Lbs. of Ice per 24 hours 70°A / 50°W	Electrical	kWh per 100 Lbs.	Shipping Weight	List F.O.B. Griffin
F-2001MWH		Water-Cooled	1642	2030	208-230V/60/1**	3.68	342 Lbs.	\$18,080
F-2001MRH		Remote A-C	1592	1990	208-230V/60/1**	4.49	360 Lbs.	\$18,080
F-2001MRH3		Remote A-C	1608	2010	208-230V/60/3*	4.33	360 Lbs.	\$18,180
F-2001MLJ		Air-Cooled	1733	2280	115V/60/1	0.6	250 Lbs.	\$16,300

Accessories
H9320-51 Recommended Water Filtration - Single Configuration \$355

Use URC-22F Condenser for Remote Air-Cooled Unit



























30 x 32 1/2 x 79 1/4 44 x 32 1/2 x 79 1/4 48 x 32 1/2 x 79 1/4 52 x 32 1/2 x 79 1/4
 Dimensions shown in W x D x H include Bins. See TOP KIT MATRIX (pg 35) for top kit options based on bin size.

CUBELET Self Contained

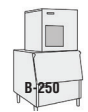
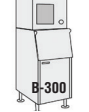
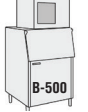
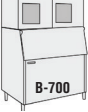

  -DS shown with Custom Cabinetry		<h2 style="color: #0070C0;">Undercounter CUBELET with Built-In Bin</h2>					Self-Contained Bin Storage Capacity Up to 22 Lbs.	
		Dimensions: 14 ^{7/8} "W X 22 ^{5/8} "D X 33 ^{1/2} "H The ADA compliant machine dimensions are 14 ^{7/8} "W x 22 ^{5/8} "D x 31 ^{1/2} "H						
Model Number	Condenser	Lbs. of Ice per 24 hours 90°A / 70°W	Lbs. of Ice per 24 hours 70°A / 50°W	Electrical	kWh per 100 Lbs.	Shipping Weight	List F.O.B. Griffin	
C-80BAJ	Air-Cooled	45	80	115V/60/1	17.3	130 Lbs.	\$5,200	
C-80BAJ-DS [†]	Air-Cooled	45	80	115V/60/1	17.3	130 Lbs.	\$5,200	
C-80BAJ-AD*	Air-Cooled	45	80	115V/60/1	17.3	130 Lbs.	\$5,200	
C-80BAJ-ADDS**	Air-Cooled	45	80	115V/60/1	17.3	130 Lbs.	\$5,460	
Accessories HS-0229 -DS Door Reversal Part (Available as a Service Part) HS-5061 Drain Pump (Beckett Brand) 1 Year Warranty - Parts & labor \$600 HS-0182 Side Trim Kit \$235 HS-2133 2" Top Spacer Kit available \$170 H9320-51 Recommended Water Filtration - Single Configuration \$355								
  								
UL approved for outdoor use [†] -DS Models - Wood Door System (Designed to accommodate custom cabinetry) *ADA compliant								

		<h2 style="color: #0070C0;">Undercounter CUBELET with Built-In Bin</h2>					Self-Contained Bin Storage Capacity Up to 80 Lbs.[†]	
		Dimensions: 24"W X 26"D X 39*"H (*6" Legs Included)						
Model Number	Condenser	Lbs. of Ice per 24 hours 90°A / 70°W	Lbs. of Ice per 24 hours 70°A / 50°W	Electrical	kWh per 100 Lbs.	Shipping Weight	List F.O.B. Griffin	
F-330BAJ-C	Air-Cooled	214	288	115V/60/1	7.3	178 Lbs.	\$7,210	
Accessories LP-6 LEG Four 6" Stainless Steel Legs Package available (optional) \$212 H9320-51 Recommended Water Filtration - Single Configuration \$355								
  								
Four 6" Legs Package (LP-6P LEG) included [†] Rated in accordance with AHRI Standard 820(I-P). Capacity based on 100% of total volume x 30 lb/ft ³ average density of ice.								

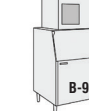
		<h2 style="color: #0070C0;">CUBELET</h2>					
		Dimensions: 22"W X 27 ^{3/8} "D X 22"H (ice machine dimensions only)					
Model Number	Condenser	Lbs. of Ice per 24 hours 90°A / 70°W	Lbs. of Ice per 24 hours 70°A / 50°W	Electrical	kWh per 100 Lbs.	Shipping Weight	List F.O.B. Griffin
F-450MAJ-C*	Air-Cooled	316	412	115V/60/1	6.10	170 Lbs.	\$6,750
Accessories H9320-51 Recommended Water Filtration - Single Configuration \$355							
  							
*Not recommended for dispensing applications							
     							
30 x 32 1/2 x 55 3/8 22 x 32 1/2 x 68 30 x 32 1/2 x 68 44 x 32 1/2 x 68 48 x 32 1/2 x 68 52 x 32 1/2 x 68 Dimensions shown in W x D x H include Bins. See TOP KIT MATRIX (pg 35) for top kit options based on bin size.							



CUBELET

F-801M_J-C



CUBELET

Dimensions: 22"W X 27^{3/8}"D X 26"H
(ice machine dimensions only)

Model Number	Condenser	Lbs. of Ice per 24 hours 90°A / 70°W	Lbs. of Ice per 24 hours 70°A / 50°W	Electrical	kWh per 100 Lbs.	Shipping Weight	List F.O.B. Griffin
F-801MAJ-C*	Air-Cooled	532	690	115V/60/1	5.00	205 Lbs.	\$8,740
F-801MWJ-C	Water-Cooled	580	632	115V/60/1	4.13	205 Lbs.	\$8,750

Accessories

HS-2110 Thermostat Kit: Required for Ice Beverage Application	\$180
HS-5034 Thermostat Kit: Required for Freestyle Applications	\$170
H9320-51 Recommended Water Filtration - Single Configuration	\$355



*ENERGY STAR qualified

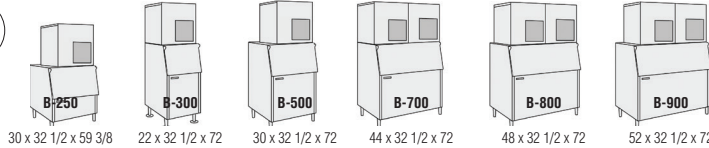

Dimensions shown in W x D x H include Bins. See TOP KIT MATRIX (pg 35) for top kit options based on bin size.

F-1002M_J-C



CUBELET

Dimensions: 22"W X 27^{3/8}"D X 26"H
(ice machine dimensions only)

Model Number	Condenser	Lbs. of Ice per 24 hours 90°A / 70°W	Lbs. of Ice per 24 hours 70°A / 50°W	Electrical	kWh per 100 Lbs.	Shipping Weight	List F.O.B. Griffin
F-1002MAJ-C	Air-Cooled	726	890	115V/60/1	4.57	210 Lbs.	\$10,510
F-1002MWJ-C	Water-Cooled	703	790	115V/60/1	3.8	210 Lbs.	\$10,510
F-1002MRJ-C	Remote A-C	680	821	115V/60/1	4.94	210 Lbs.	\$10,460

Accessories

HS-2110 Thermostat Kit: Required for Ice Beverage Application	\$180
H9320-51 Recommended Water Filtration - Single Configuration	\$355



Use URC-5F Condenser for Remote Air-Cooled Unit

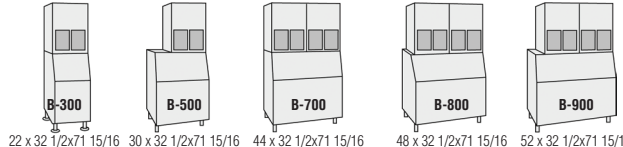

Dimensions shown in W x D x H include Bins. See TOP KIT MATRIX (pg 35) for top kit options based on bin size.

F-1501M_J-C



CUBELET

Dimensions: 30"W X 27^{3/8}"D X 34^{7/16}"H
(ice machine dimensions only)

Model Number	Condenser	Lbs. of Ice per 24 hours 90°A / 70°W	Lbs. of Ice per 24 hours 70°A / 50°W	Electrical	kWh per 100 Lbs.	Shipping Weight	List F.O.B. Griffin
F-1501MAJ-C	Air-Cooled	1020	1327	208-230V/60/1**	4.61	325 Lbs.	\$13,220
F-1501MWJ-C	Water-Cooled	1218	1376	208-230V/60/1**	3.76	325 Lbs.	\$13,220
F-1501MRJ-C	Remote A-C	1125	1335	208-230V/60/1**	4.35	315 Lbs.	\$13,110

Accessories

H9320-51 Recommended Water Filtration - Single Configuration	\$355
--	-------



Use URC-14F Condenser for Remote Air-Cooled Unit

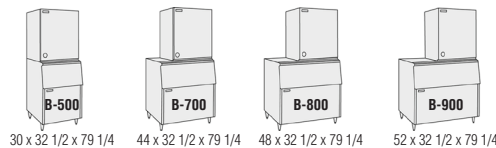



Dimensions shown in W x D x H include Bins. See TOP KIT MATRIX (pg 35) for top kit options based on bin size.

CUBELET



F-2001MRH-C







CUBELET





Dimensions: 30"W x 27 1/2"D x 34 7/16"H
(ice machine dimensions only)

Model Number	Condenser	Lbs. of Ice per 24 hours 90°A / 70°W	Lbs. of Ice per 24 hours 70°A / 50°W	Electrical	kWh per 100 Lbs.	Shipping Weight	List F.O.B. Griffin
F-2001MRH-C	Remote A-C	1496	1814	208-230V/60/1**	5.1	360 Lbs.	\$18,560

Accessories
H9320-51 Recommended Water Filtration - Single Configuration \$355

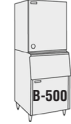
Use URC-22F Condenser for Remote Air-Cooled Unit







30 x 32 1/2 x 79 1/4 44 x 32 1/2 x 79 1/4 48 x 32 1/2 x 79 1/4 52 x 32 1/2 x 79 1/4

Dimensions shown in W x D x H include Bins. See TOP KIT MATRIX (pg 35) for top kit options based on bin size.

FD-650M_H-C









CUBELET

Dimensions: 22"W X 24"D X 26"H
(ice machine dimensions only)

Model Number	Condenser	Lbs. of Ice per 24 hours 90°A / 70°W	Lbs. of Ice per 24 hours 70°A / 50°W	Electrical	kWh per 100 Lbs.	Shipping Weight	List F.O.B. Griffin
FD-650MAH-C	Air-Cooled	474	650	115V/60/1	5.35	205 Lbs.	\$7,980
FD-650MWH-C	Water-Cooled	532	615	115V/60/1	3.81	205 Lbs.	\$7,980
FD-650MRH-C*	Remote A-C	476	590	115V/60/1	4.75	205 Lbs.	\$7,880

Accessories
H9320-51 Recommended Water Filtration - Single Configuration \$355

Use URC-5F Condenser for Remote Air-Cooled Unit

***ENERGY STAR qualified**



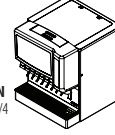
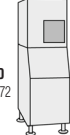

Lancer SENSATION
30 x 31 x 37 1/4

BD-300
22 x 24 x 72

Dimensions shown in W x D x H include Bins. See TOP KIT MATRIX (pg 35) for top kit options based on bin size.

FD-1002M_J-C







CUBELET



Dimensions: 22"W X 24"D X 26"H
(ice machine dimensions only)

Model Number	Condenser	Lbs. of Ice per 24 hours 90°A / 70°W	Lbs. of Ice per 24 hours 70°A / 50°W	Electrical	kWh per 100 Lbs.	Shipping Weight	List F.O.B. Griffin
FD-1002MAJ-C	Air-Cooled	726	890	115V/60/1	4.57	210 Lbs.	\$11,150
FD-1002MRJ-C	Remote A-C	680	821	115V/60/1	4.94	210 Lbs.	\$10,980

Accessories
H9320-51 Recommended Water Filtration - Single Configuration \$355

Use URC-5F Condenser for Remote Air-Cooled Unit

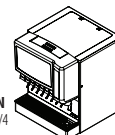
Lancer SENSATION
30 x 31 x 37 1/4

BD-300
22 x 24 x 72

Dimensions shown in W x D x H include Bins. See TOP KIT MATRIX (pg 35) for top kit options based on bin size.



CUBELET Serenity

FS-1001MLH-C



CUBELET

Dimensions: 30"W X 11"D X 26"H
(ice machine dimensions only)



Model Number	Condenser	Lbs. of Ice per 24 hours 90°A / 70°W 70°A / 50°W	Electrical	kWh per 100 Lbs. 90°A / 70°W 70°A / 50°W	Shipping Weight	List F.O.B. Griffin
FS-1001MLH-C	Remote A-C	705 830	115V/60/1	5.96 4.94	166 Lbs.	\$9,860

Accessories

H9320-51 Recommended Water Filtration - Single Configuration

\$355



Use SRC-10H Condenser for Remote Air-Cooled Unit

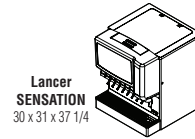

Dimensions shown in W x D x H include Bins. See TOP KIT MATRIX (pg 35) for top kit options based on bin size.

FS-1022MLH-C



CUBELET

Dimensions: 22"W X 16 1/2"D X 26"H
(ice machine dimensions only)



Model Number	Condenser	Lbs. of Ice per 24 hours 90°A / 70°W 70°A / 50°W	Electrical	kWh per 100 Lbs. 90°A / 70°W 70°A / 50°W	Shipping Weight	List F.O.B. Griffin
FS-1022MLH-C	Remote A-C	705 830	115V/60/1	5.96 4.94	166 Lbs.	\$9,860

Accessories

H9320-51 Recommended Water Filtration - Single Configuration

\$355



Use SRC-10H Condenser for Remote Air-Cooled Unit

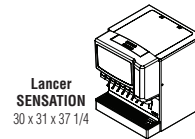

Dimensions shown in W x D x H include Bins. See TOP KIT MATRIX (pg 35) for top kit options based on bin size.

FS-1500MLH-C



CUBELET

Dimensions: 30"W X 16 1/2"D X 33"H
(ice machine dimensions only)



Model Number	Condenser	Lbs. of Ice per 24 hours 90°A / 70°W 70°A / 50°W	Electrical	kWh per 100 Lbs. 90°A / 70°W 70°A / 50°W	Shipping Weight	List F.O.B. Griffin
FS-1500MLH-C	Remote A-C	1165 1420	115V/60/1	4.51 3.55	222 Lbs.	\$12,390

Accessories

H9320-51 Recommended Water Filtration - Single Configuration

\$355



Use SRC-14H Condenser for Remote Air-Cooled Unit

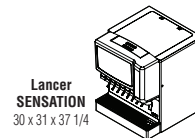







Dimensions shown in W x D x H include Bins. See TOP KIT MATRIX (pg 35) for top kit options based on bin size.









DISPENSER



Features & Benefits of HOSHIZAKI Dispensers

- Attractive stainless steel exterior provides long life and easy maintenance
- **KMEdge** dispensers feature a built-in insulated storage bin
- Three dimensional agitation prevents clumping and assists in delivering ice conveniently
- **DKM Hotel Dispenser** features the industry's only one-piece design and is 35% quieter than other hotel dispensers
- **DB Series** accommodates KM Series & KMEdge cubers
- **DCM Series** dispenses easy to chew cubelet ice and water
- HOSHIZAKI's **DCM Opti-Serve™ Series** offers hands-free dispensing and helps eliminate the possibility of cross-contamination
- All dispensers feature built-in ice storage capacity

DCM-270BAH		CUBELET Ice & Water Dispenser						
		Dimensions: 16 9/16" W X 24 1/8" D X 31 11/16" H (*4" Legs Included - dispenser dimensions only)					Ice Bin Storage Capacity Up to 10 Lbs.†	
	Model Number	Condenser	Lbs. of Ice per 24 hours 90° A / 70° W	Lbs. of Ice per 24 hours 70° A / 50° W	Electrical	kWh per 100 Lbs.	Shipping Weight	List F.O.B. Griffin
	DCM-270BAH	Air-Cooled	215	282	115V/60/1	7.6	170 Lbs.	\$7,420
Accessories LP-4 LEG Four 4" Stainless Steel Legs Package available (optional) \$191 SD-270 Equipment Stand \$1,210 HS-2070 Seismic Wall Mount Kit \$170 HS-2104 Wall Mount Kit \$785 H9320-51 Recommended Water Filtration - Single Configuration \$355								
		  					Counter-Top with 4" Legs 16 9/16 x 24 1/8 x 31 11/16 W x D x H	
Four 4" Legs included †Rated in accordance with AHRI Standard 820(I-P). Capacity based on 100% of total volume x 30 lb/ft³ average density of ice.								

DCM-300BAH		CUBELET Ice & Water Dispenser							
		Dimensions: 26" W X 22 1/2" D X 40" H (ice machine / dispenser dimensions only)					Ice Bin Storage Capacity Up to 40 Lbs.†		
	Model Number	Condenser	Lbs. of Ice per 24 hours 90° A / 70° W	Lbs. of Ice per 24 hours 70° A / 50° W	Electrical	kWh per 100 Lbs.	Shipping Weight	List F.O.B. Griffin	
	DCM-300BAH	Air-Cooled	232	321	115V/60/1	6.84	240 Lbs.	\$9,480	
Accessories LP-6P LEG Four 6" Painted Legs Package available \$201 LP-6 LEG Four 6" Stainless Steel Legs Package available \$212 SD-500 Equipment Stand \$1,310 Leg Kits: HS-2066 Seismic Wall Mount Kit \$180 HS-2071 Leg Seismic Kit \$380 H9320-51 Recommended Water Filtration - Single Configuration \$355									
		  			  			Floor Model with Optional Stand 26 x 22 1/2 x 72 1/2 W x D x H	
Unit supplied without legs †Rated in accordance with AHRI Standard 820(I-P). Capacity based on 100% of total volume x 30 lb/ft³ average density of ice.									



DISPENSER

DCM-500B_H

CUBELET Ice & Water Dispenser

Dimensions: 26"W X 22 1/2"D X 40"H
(ice machine / dispenser dimensions only)

**Ice Bin Storage Capacity
Up to 40 Lbs.†**

Model Number	Condenser	Lbs. of Ice per 24 hours 90°A / 70°W	Lbs. of Ice per 24 hours 70°A / 50°W	Electrical	kWh per 100 Lbs.	Shipping Weight	List F.O.B. Griffin
DCM-500BAH	Air-Cooled	450	618	115V/60/1	5.62	276 Lbs.	\$11,340
DCM-500BWH	Water-Cooled	512	590	115V/60/1	4.48	269 Lbs.	\$11,340

Accessories

LP-6P LEG Four 6" Painted Legs Package available \$201

LP-6 LEG Four 6" Stainless Steel Legs Package available \$212

SD-500 Equipment Stand \$1,310

Leg Kits: **HS-2066** Seismic Wall Mount Kit \$180

HS-2071 Leg Seismic Kit \$380

H9320-51 Recommended Water Filtration - Single Configuration \$355

AHRI CERTIFIED
Approved Component for Models
MH48989

UL
CERTIFIED
UL 60032
MH48989

NSF

Unit supplied without legs
†Rated in accordance with AHRI Standard 820(I-P).
Capacity based on 100% of total volume x 30 lb/ft³ average density of ice.

Counter-Top
 26 x 22 1/2 x 40
 W x D x H

**Counter-Top
with Optional 6" Legs**
 26 x 22 1/2 x 46
 W x D x H

**Floor Model
with Optional Stand**
 26 x 22 1/2 x 72 1/2
 W x D x H

DCM-751B_H

CUBELET Ice & Water Dispenser

Dimensions: 34 1/16"W X 28 1/2"D X 48 1/16"H
(ice machine / dispenser dimensions only)

**Ice Bin Storage Capacity
Up to 95 Lbs.†**

Model Number	Condenser	Lbs. of Ice per 24 hours 90°A / 70°W	Lbs. of Ice per 24 hours 70°A / 50°W	Electrical	kWh per 100 Lbs.	Shipping Weight	List F.O.B. Griffin
DCM-751BAH	Air-Cooled	583	801	115V/60/1	5.94	345 Lbs.	\$15,760
DCM-751BWH	Water-Cooled	678	782	115V/60/1	4.76	345 Lbs.	\$15,760

Accessories

LP-6P LEG Four 6" Painted Legs Package available \$201

LP-6 LEG Four 6" Stainless Steel Legs Package available \$212

SD-750 Equipment Stand \$1,650

Leg Kits: **HS-2067** Seismic Wall Mount Kit \$225

HS-2072 Leg Seismic Kit \$380

H9320-51 Recommended Water Filtration - Single Configuration \$355

AHRI CERTIFIED
Approved Component for Models
MH48989

UL
CERTIFIED
UL 60032
MH48989

NSF

Unit supplied without legs
†Rated in accordance with AHRI Standard 820(I-P).
Capacity based on 100% of total volume x 30 lb/ft³ average density of ice.

Counter-Top
 34 1/16 x 28 1/2 x 48 1/16
 W x D x H

**Counter-Top
with Optional 6" Legs**
 34 1/16 x 28 1/2 x 54 1/16
 W x D x H

**Floor Model
with Optional Stand**
 34 1/16 x 28 1/2 x 80 1/2
 W x D x H

DCM-270BAH-OS

CUBELET Ice & Water Opti-Serve™ Dispenser

Hands-free sensor designed for use with opaque containers. Not intended for outdoor use - avoid placement in direct sunlight.

Dimensions: 16 9/16"W X 24 1/8"D X 31 11/16"H
(ice machine / dispenser dimensions only)

**Ice Bin Storage Capacity
Up to 10 Lbs.†**

Model Number	Condenser	Lbs. of Ice per 24 hours 90°A / 70°W	Lbs. of Ice per 24 hours 70°A / 50°W	Electrical	kWh per 100 Lbs.	Shipping Weight	List F.O.B. Griffin
DCM-270BAH-OS	Air-Cooled	220	288	115V/60/1	7.3	170 Lbs.	\$7,520

Accessories

LP-4 LEG Four 4" Stainless Steel Legs Package available \$191

SD-270 Equipment Stand \$1,210

HS-2070 Seismic Wall Mount Kit \$170

HS-2104 Wall Mount Kit \$785

H9320-51 Recommended Water Filtration - Single Configuration \$355

AHRI CERTIFIED
Approved Component for Models
MH48989

UL
CERTIFIED
UL 60032
MH48989

NSF

Four 4" Legs included
†Rated in accordance with AHRI Standard 820(I-P).
Capacity based on 100% of total volume x 30 lb/ft³ average density of ice.

**Counter-Top
with 4" Legs**
 16 9/16 x 24 1/8 x 31 11/16
 W x D x H

DISPENSER



DCM-300BAH-OS

CUBELET Ice & Water Opti-Serve™ Dispenser

Hands-free sensor designed for use with opaque containers. Not intended for outdoor use - avoid placement in direct sunlight.

Dimensions: 26"W X 22 1/2"D X 40"H
(ice machine / dispenser dimensions only)

**Ice Bin Storage Capacity
Up to 40 Lbs.†**

Model Number	Condenser	Lbs. of Ice per 24 hours 90°A / 70°W	Lbs. of Ice per 24 hours 70°A / 50°W	Electrical	kWh per 100 Lbs.	Shipping Weight	List F.O.B. Griffin
DCM-300BAH-OS	Air-Cooled	232	321	115V/60/1	6.84	240 Lbs.	\$9,580

Accessories

LP-6P LEG Four 6" Painted Legs Package available \$201

LP-6 LEG Four 6" Stainless Steel Legs Package available \$212

SD-500 Equipment Stand \$1,310

Leg Kits: **HS-2066** Seismic Wall Mount Kit \$180

HS-2071 Leg Seismic Kit \$380

H9320-51 Recommended Water Filtration - Single Configuration \$355

Unit supplied without legs

†Rated in accordance with AHRI Standard 820(I-P).
Capacity based on 100% of total volume x 30 lb/ft³ average density of ice.

Counter-Top
26 x 22 1/2 x 40
W x D x H

**Counter-Top
with Optional 6" Legs**
26 x 22 1/2 x 46
W x D x H

**Floor Model
with Optional Stand**
26 x 22 1/2 x 72 1/2
W x D x H

DCM-500B_H-OS

CUBELET Ice & Water Opti-Serve™ Dispenser

Hands-free sensor designed for use with opaque containers. Not intended for outdoor use - avoid placement in direct sunlight.

Dimensions: 26"W X 22 1/2"D X 40"H
(ice machine / dispenser dimensions only)

**Ice Bin Storage Capacity
Up to 40 Lbs.†**

Model Number	Condenser	Lbs. of Ice per 24 hours 90°A / 70°W	Lbs. of Ice per 24 hours 70°A / 50°W	Electrical	kWh per 100 Lbs.	Shipping Weight	List F.O.B. Griffin
DCM-500BAH-OS	Air-Cooled	450	618	115V/60/1	5.62	276 Lbs.	\$11,440
DCM-500BWH-OS	Water-Cooled	512	590	115V/60/1	4.48	269 Lbs.	\$11,440

Accessories

LP-6P LEG Four 6" Painted Legs Package available \$201

LP-6 LEG Four 6" Stainless Steel Legs Package available \$212

SD-500 Equipment Stand \$1,310

Leg Kits: **HS-2066** Seismic Wall Mount Kit \$180

HS-2071 Leg Seismic Kit \$380

H9320-51 Recommended Water Filtration - Single Configuration \$355

Unit supplied without legs

†Rated in accordance with AHRI Standard 820(I-P).
Capacity based on 100% of total volume x 30 lb/ft³ average density of ice.

Counter-Top
26 x 22 1/2 x 40
W x D x H

**Counter-Top
with Optional 6" Legs**
26 x 22 1/2 x 46
W x D x H

**Floor Model
with Optional Stand**
26 x 22 1/2 x 72 1/2
W x D x H



DISPENSER

DCM-751B_H-OS



CUBELET Ice & Water Opti-Serve™ Dispenser

Hands-free sensor designed for use with opaque containers. Not intended for outdoor use - avoid placement in direct sunlight.

Dimensions: 34 1/16"W X 28 1/2"D X 48 1/16"H
(ice machine / dispenser dimensions only)

Ice Bin Storage Capacity
Up to 95 Lbs.†

Model Number	Condenser	Lbs. of Ice per 24 hours 90°A / 70°W	Lbs. of Ice per 24 hours 70°A / 50°W	Electrical	kWh per 100 Lbs.	Shipping Weight	List F.O.B. Griffin
DCM-751BAH-OS	Air-Cooled	583	801	115V/60/1	5.94	345 Lbs.	\$15,860
DCM-751BWH-OS	Water-Cooled	678	782	115V/60/1	4.76	345 Lbs.	\$15,860

Accessories: **LP-6P LEG** Four 6" Painted Legs Package available \$201
LP-6 LEG Four 6" Stainless Steel Legs Package available \$212
SD-750 Equipment Stand \$1,650
 Leg Kits: **HS-2067** Seismic Wall Mount Kit \$225
HS-2072 Leg Seismic Kit \$380
H9320-51 Recommended Water Filtration - Single Configuration \$355



Unit supplied without legs

†Rated in accordance with AHRI Standard 820(I-P).
Capacity based on 100% of total volume x 30 lb/ft³ average density of ice.

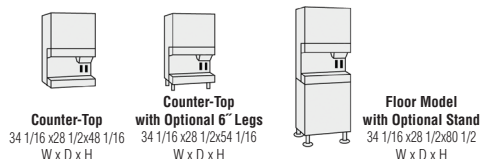

DB-130H



KMEdge DB Dispenser

Dimensions: 22"W X 30"D X 53"H
(*6" Legs Included - dispenser dimensions only)

Model Number	Application Ice Storage Capacity	Dispensing Rate	Electrical	Icemaker kWh per 100 lbs.	Shipping Weight	List F.O.B. Griffin
DB-130H	130 Lbs.	20 lbs./min.	115V/60/1	N/A	215 Lbs.	\$4,970

Accessories: **LP-6 FLANGE LEG** Four 6" Stainless Steel Legs Package available \$255
HS-2109 Chute/grill \$308



CANADIAN ENERGY PERFORMANCE VERIFIED
RENDEMENT ENERGETIQUE VERIFIE

Four Painted 6" Flange Legs included
Note: 90 Day Warranty on accessory parts
Ice dispensing area is ADA compliant

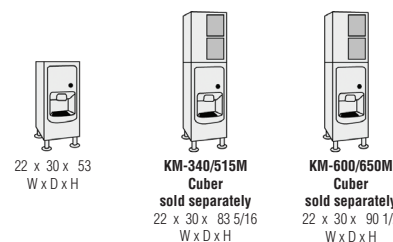

DB-200H



KMEdge DB Dispenser

Dimensions: 30"W X 30"D X 53"H
(*6" Legs Included - dispenser dimensions only)

Model Number	Application Ice Storage Capacity	Dispensing Rate	Electrical	Icemaker kWh per 100 lbs.	Shipping Weight	List F.O.B. Griffin
DB-200H	200 Lbs.	13 lbs./min.	115V/60/1	N/A	240 Lbs.	\$5,590

Accessories: **HS-2036** Top Kit for KM-340M, KM-515M, KM-600M or KM-650M \$191
LP-6 LEG Four 6" Stainless Steel Legs Package available \$212
HS-2109 Chute/grill \$308







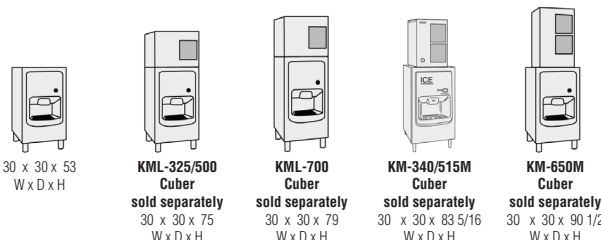

CANADIAN ENERGY PERFORMANCE VERIFIED
RENDEMENT ENERGETIQUE VERIFIE





Four Painted 6" Flange Legs included
Note: 90 Day Warranty on accessory parts
Ice dispensing area is ADA compliant



DISPENSER

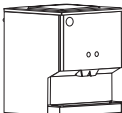
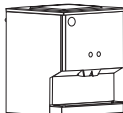

		KMEdge DKM Dispenser					
		Dimensions: 30"W X 28"D X 77"H (*6" Legs Included)					
Model Number	Lbs. of Ice per 24 hours 70" A / 50" W	Application Ice Storage Capacity	Dispensing Rate	Electrical	Icemaker kWh per 100 lbs.	Shipping Weight	List F.O.B. Griffin
*DKM-500BAJ DKM-500BWJ	545 Lbs. 540 Lbs.	200 Lbs. 200 Lbs.	13 lbs. / min. 13 lbs. / min.	115V/60/1 115V/60/1	5.56 4.79	410 Lbs. 372 Lbs.	\$11,470 \$11,470
Accessories: HS-3586 6" Casters - Set of 4 \$435 H9320-51 Recommended Water Filtration - Single Configuration \$355							
    Rated in accordance with AHRI Standard 820							
Four 6" Legs included DKM-500B - Ice dispensing area is ADA compliant *ENERGY STAR qualified							

		KM & KMEdge DM Dispenser						
		Dimensions: 30"W X 28"D X 36 3/8"H						
Model Number	Application Ice Storage Capacity	Dispensing Rate	Electrical	Icemaker Production per 24 hrs.	Icemaker kWh per 100 lbs.	Shipping Weight	List F.O.B. Griffin	
DM-200B	200 lbs.	7.5 lbs. / min.	115-120V/60/1	N/A	N/A	240 Lbs.	\$5,740	
Accessories: HS-2036 Top Kit for KM-340M, KM-515M, KM-600M or KM-650M \$191 DM Legs Four 4" Black Die Cast Legs Kit \$160 SD-200 Equipment Stand \$1,630								
   CANADIAN ENERGY PERFORMANCE VERIFIED RENDEMENT ENERGETIQUE VERIFIE								
Unit supplied without legs								
				 Counter-Top 30 x 28 x 36 3/8 W x D x H	 Counter-Top with optional 4" legs 30 x 28 x 40 3/8 W x D x H			



ICE STORAGE BINS



HOSHIZAKI Ice Storage Bins are available with either stainless steel or vinyl clad exterior for easy cleaning and long lasting attractive appearance. Sturdy construction for side-by-side or stacked installations and non-corrosive bin liner provide safe, sanitary storage of cubed or flaked ice. Foamed-in-place polyurethane insulation in all bin walls and bottom provides dependable ice storage. H-GUARD Plus® Antimicrobial Agent adds extra protection to the ice scoop. (included)



CANADIAN ENERGY
PERFORMANCE VERIFIED
RENDEMENT ENERGETIQUE VERIFIE







Intertek Intertek

B-250PF		Model Number	Exterior Finish	Application Ice Storage Capacity	Dimensions W x D x H (Height includes 6" legs)	Shipping Weight	List F.O.B. Griffin	
		B-250PF	Vinyl Clad	250 Lbs.	30" x 32 1/2" x 33 3/8"	130 Lbs.	\$1,620	
	Accessories							
	LP-6 LEG Four 6" Stainless Steel Legs Package available \$212 HS-2033 Order 8" Top Kit to accommodate 22"W ice machines \$201 Four 6" Painted Legs included Refer to Top Kit Matrix for necessary configurations							
B-300PF / SF BD-300PF / SF**		Model Number	Exterior Finish	Application Ice Storage Capacity	Dimensions W x D x H (Height includes 6" legs)	Shipping Weight	List F.O.B. Griffin	
		B-300SF	Stainless Steel	300 Lbs.	22" x 32 1/2" x 46"	135 Lbs.	\$1,850	
		B-300PF	Vinyl Clad	300 Lbs.	22" x 32 1/2" x 46"	135 Lbs.	\$1,740	
	Accessories							
	LP-6 FLANGE LEG Four 6" Stainless Steel Flange Legs Package available \$255 Four 6" Painted Legs included Refer to Top Kit Matrix for necessary configurations							
			BD-300SF	Stainless Steel	300 Lbs.	22" x 32 1/2" x 46"	135 Lbs.	\$1,890
		BD-300PF	Vinyl Clad	300 Lbs.	22" x 32 1/2" x 46"	135 Lbs.	\$1,780	
Accessories								
LP-6 FLANGE LEG Four 6" Stainless Steel Flange Legs Package available \$255 For use with KMD-410M, KMS-822M, FD-650M-C, FD-1001M-C **BD Bins fit 24" to 24 1/2" deep Ice Machines without Top Kit extension Four 6" Flange Legs included								
B-500PF / SF BD-500PF / SF**		Model Number	Exterior Finish	Application Ice Storage Capacity	Dimensions W x D x H (Height includes 6" legs)	Shipping Weight	List F.O.B. Griffin	
		B-500SF	Stainless Steel	500 Lbs.	30" x 32 1/2" x 46"	155 Lbs.	\$2,030	
		B-500PF	Vinyl Clad	500 Lbs.	30" x 32 1/2" x 46"	155 Lbs.	\$1,930	
	Accessories							
	LP-6 LEG Four 6" Stainless Steel Legs Package available \$212 HS-2033 Order 8" Top Kit to accommodate 22"W ice machines \$201 HS-2129 Top Kit: KMD application \$255 Four 6" Painted Legs included Refer to Top Kit Matrix for necessary configurations							
			BD-500SF	Stainless Steel	500 Lbs.	30" x 32 1/2" x 46"	155 Lbs.	\$2,050
		BD-500PF	Vinyl Clad	500 Lbs.	30" x 32 1/2" x 46"	155 Lbs.	\$1,950	
Accessories								
LP-6 LEG Four 6" Stainless Steel Legs Package available \$212 For use with KMD-460M, KMD-530M, KMD-850M **BD Bins fit 24" to 24 1/2" deep Ice Machines without Top Kit extension Four 6" Painted Legs included								

ICE STORAGE BINS



B-700PF / SF		Model Number	Exterior Finish	Application Ice Storage Capacity	Dimensions W x D x H (Height includes 6" legs)	Shipping Weight	List F.O.B. Griffin
	B-700SF		Stainless Steel	700 Lbs.	44" x 32 1/2" x 46"	200 Lbs.	\$2,450
	B-700PF		Vinyl Clad	700 Lbs.	44" x 32 1/2" x 46"	200 Lbs.	\$2,290
Accessories							
LP-6 LEG Four 6" Stainless Steel Legs Package available							\$212
HS-2035 Order 22" Top Kit to accommodate 22"W ice machines							\$225
HS-2034 Order 14" Top Kit to accommodate 30"W ice machines							\$212
HS-2130 Top Kit: KMD application							\$288
Four 6" Painted Legs included							
Refer to Top Kit Matrix for necessary configurations							
B-800PF / SF		Model Number	Exterior Finish	Application Ice Storage Capacity	Dimensions W x D x H (Height includes 6" legs)	Shipping Weight	List F.O.B. Griffin
	B-800SF		Stainless Steel	800 Lbs.	48" x 32 1/2" x 46"	210 Lbs.	\$2,680
	B-800PF		Vinyl Clad	800 Lbs.	48" x 32 1/2" x 46"	210 Lbs.	\$2,520
Accessories							
LP-6 LEG Four 6" Stainless Steel Legs Package available							\$212
HS-2035 22" Top Kit & HS-2032 - 4" Top Kit to accommodate 22"W ice machines							\$416
HS-2032 4" Top Kit to accommodate (2) 22"W ice machines							\$191
HS-2034 Order 14" Top Kit & HS-2032 - 4" Top Kit to accommodate 30"W machines							\$403
HS-2131 Top Kit: KMD application							\$350
Four 6" Painted Legs included							
Refer to Top Kit Matrix for necessary configurations							
B-900PF / SF		Model Number	Exterior Finish	Application Ice Storage Capacity	Dimensions W x D x H (Height includes 6" legs)	Shipping Weight	List F.O.B. Griffin
	B-900SF		Stainless Steel	900 Lbs.	52" x 32 1/2" x 46"	220 Lbs.	\$2,890
	B-900PF		Vinyl Clad	900 Lbs.	52" x 32 1/2" x 46"	220 Lbs.	\$2,730
Accessories							
LP-6 LEG Four 6" Stainless Steel Legs Package available							\$212
HS-2035 Order 22" Top Kit to accommodate 30"W ice machines							\$225
HS-2035 22" Top Kit & HS-2033 - 8" Top Kit to accommodate 22"W ice machines							\$426
HS-2033 8" Top Kit to accommodate (2) 22"W machines							\$201
HS-2032 4" Top Kit to accommodate 48"W ice machines							\$191
HS-2132 Top Kit: KMD application							\$425
Four 6" Painted Legs included							
Refer to Top Kit Matrix for necessary configurations							
B-1150SS / B-1300SS		Model Number	Exterior Finish	Application Ice Storage Capacity	Dimensions W x D x H (Height includes 6" legs)	Shipping Weight	List F.O.B. Griffin
	B-1150SS		Stainless Steel	1148 Lbs.	48" x 41" x 60"	345 Lbs.	\$5,660
	B-1300SS		Stainless Steel	1304 Lbs.	48" x 41" x 66"	365 Lbs.	\$5,770
Accessories							
LP-6 LEG Four 6" Stainless Steel Legs Package available							\$212
*Depth including 10" for door installation							
Four 6" Die-cast Legs included, baffle design increases ice accessibility by 30%							
Universal top included - Check Top Kit Application Guide for detail							
B-1500SS / B-1650SS		Model Number	Exterior Finish	Application Ice Storage Capacity	Dimensions W x D x H (Height includes 6" legs)	Shipping Weight	List F.O.B. Griffin
	B-1500SS		Stainless Steel	1500 Lbs.	60" x 41" x 62"	395 Lbs.	\$6,450
	B-1650SS		Stainless Steel	1605 Lbs.	60" x 41" x 66"	415 Lbs.	\$6,730
Accessories							
LP-6 LEG Four 6" Stainless Steel Legs Package available							\$212
*Depth including 10" for door installation							
Four 6" Die-cast Legs included, baffle design increases ice accessibility by 30%							
Universal top included - Check Top Kit Application Guide for detail							



DISPENSER STAND

SD STANDS DM and DCM Series Dispensers	Model Number	Use with Ice Machine / Dispenser Model	Dimensions W x D x H (Height includes 6" legs)	Shipping Weight	List F.O.B. Griffin
	SD-200	DM-200B	30" x 28" x 32 13/16"	125 lbs.	\$1,630
	SD-270	DCM-270 (-OS)	16 1/2" x 24" x 35 3/16"	95 lbs.	\$1,210
	SD-500	DCM-300 (-OS) / DCM-500 (-OS)	25 7/8" x 22" x 32 3/4"	100 lbs.	\$1,310
	SD-750	DCM-751 (-OS)	34" x 28" x 32 3/4"	125 lbs.	\$1,650
Accessories LP-6 FLANGE LEG Four 6" Stainless Steel Flange Legs Package available (optional) \$255 Leg Kits: HS-2066 Seismic Kit for SD 500 Stands \$180 HS-2071 Leg Seismic Kit SD 500 Stands \$380 Four 6" Painted Legs included					

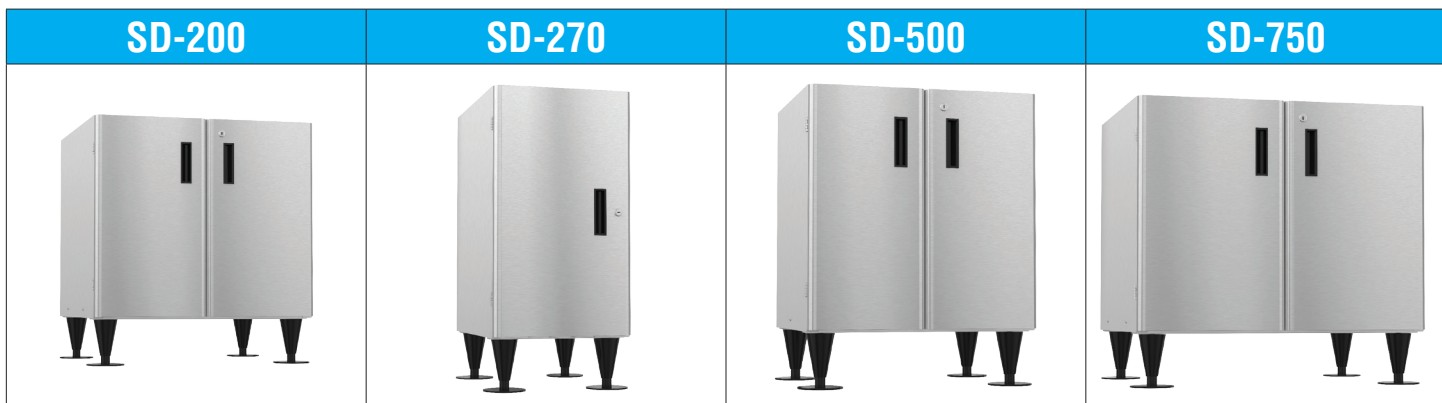

- Heavy duty stands for floor model ice machines/dispensers
- Easy cleaning and maintenance
- Attractive stainless steel exterior
- Locking doors standard



HCD ICE BAGGING SYSTEM SERIES	Model Number	Exterior Finish	Application Ice Storage Capacity	Dimensions W x D x H	Shipping Weight	List F.O.B. Griffin
	HCD-500B	Stainless Steel	647 Lbs.	30" x 36" x 71"	510 Lbs.	\$18,250
	HCD-1000B	Stainless Steel	1078 Lbs.	48" x 36" x 71"	590 Lbs.	\$23,300
48" heavy duty ice paddle included						



TOP KIT MATRIX



	22" Width	22" Width	30" Width	30" Width	44" Width	44" Width	48" Width	60" Width
	KM-340M KM-515M KM-600M KM-650M F-450M F-801M F-1001M F-1002M	KMD-410M [†] KMS-822M [†] FD-650M-C [†] FD-1002M-C [†]	KM-901M KM-1100M KM-1340M KM-1601M KML Series F-1501M F-2001M	KMD-460M [‡] KMD-530M [‡] KMD-850M [‡] KMD-901MRH KMD-901MWH KMS-1401M KMS-2000M	2 KM-340M 2 KM-515M 2 KM-600M 2 KM-650M IM-500S* 2 F-450M 2 F-801M 2 F-1001M 2 F-1002M	2 KMD-410M 2 KM-822M 2 FD-650M-C 2 FD-1002M-C	KM-1301S KM-1601S KM-1900S KM-2100S KM-2500S	2 KM-901M [¶] 2 KM-1100M 2 KM-1340M 2 KM-1601M 2 KML Series 2 F-1501M 2 F-2001M 2 KMD-850M 2 KMD-901M
22" Width B-300PF/SF DB-130H	NO TOP KIT NEEDED <i>(DB-130H-KM Only)</i>	N/A	N/A	N/A	N/A	N/A	N/A	N/A
30" Width B-250PF B-500PF/SF	NEED HS-2033	NEED HS-2033 & HS-2129	NO TOP KIT NEEDED	NEED HS-2129	N/A	N/A	N/A	N/A
44" Width B-700PF/SF	NEED HS-2035	NEED HS-2035 & HS-2130	NEED HS-2034	NEED HS-2130 & HS-2034	NO TOP KIT NEEDED	NEED HS-2130	N/A	N/A
48" Width B-800PF/SF	NEED HS-2035 & HS-2032	NEED HS-2035, HS-2032 & HS-2131	NEED HS-2034 & HS-2032	NEED HS-2131, HS-2034 & HS-2032	NEED HS-2032	NEED HS-2032 & HS-2131	NO TOP KIT NEEDED	N/A
48" Width B-1150SS B-1300SS	UNIVERSAL TOP KIT INCLUDED	N/A	UNIVERSAL TOP KIT INCLUDED	UNIVERSAL TOP KIT INCLUDED NEED HS-2147	N/A	N/A	UNIVERSAL TOP KIT INCLUDED	N/A
52" Width B-900PF/SF	NEED HS-2035 & HS-2033	NEED HS-2035 & HS-2033/2132	NEED HS-2035	NEED HS-2132 & HS-2035	NEED HS-2033	NEED HS-2033 & HS-2132	NEED HS-2032	N/A
60" Width B-1500SS B-1650SS	N/A	N/A	UNIVERSAL TOP KIT INCLUDED NEED HS-2111	N/A	UNIVERSAL TOP KIT INCLUDED <i>*(N/A for IM-500)</i>	N/A	UNIVERSAL TOP KIT INCLUDED	UNIVERSAL TOP KIT INCLUDED
30" Width DB-200H DM-200B	NEED HS-2036 <i>(KM Units Only)</i>	N/A	NO TOP KIT NEEDED <i>(KML Units Only)</i>	N/A	N/A	N/A	N/A	N/A

[†]BD-300PF/SF: bin fits KMD-410M, KMS-822M, FD-650M-C, & FD-1002M-C without a top kit extension

[‡]BD-500PF/SF: bin fits KMD-460M, KMD-530M, & KMD-850M without a top kit extension

Any KMS[§] FD on bin need Top Kit Extension:

Model Number	For Use With	List F.O.B. Griffin
HS-2129	B-500 bins	\$255
HS-2130	B-700 bins	\$288
HS-2131	B-800 bins	\$350
HS-2132	B-900 bins	\$425
HS-2147	B-1150 & 1300 bins	\$225

Model Number	Description	List F.O.B. Griffin
HS-2032	4" ABS Top Kit	\$191
HS-2033	8" ABS Top Kit	\$201
HS-2034	14" ABS Top Kit	\$212
HS-2035	22" ABS Top Kit	\$225
HS-2036	(2) 4" ABS Top Kits	\$191
HS-2111	11.3" x 26.2" Stainless Cover/Separator	FREE
HS-2148	30" x 3.1" Stainless Cover	\$160
[¶] HS-2160	2 KM-901M	\$810

[§]Excludes KMS-830MLH

BD Bin Applications - See Ice Storage Bins
KMH-2000S - Kloppenberg Bins Only



REMOTE CONDENSER

AIR-COOLED REMOTE CONDENSERS - URC / SRC / SRK

An Ice Machine with a **Remote Air Condenser** provides quiet operation at the icemaker location, improves efficiency, and saves energy with cooler operation. Sturdy construction and weather-resistant cabinet finish provides long life operation. Remote condensers may be installed outdoors up to 55 feet from the icemaker. For installations exceeding 55 feet, contact a Factory Technical Service Representative at 800-233-1940.

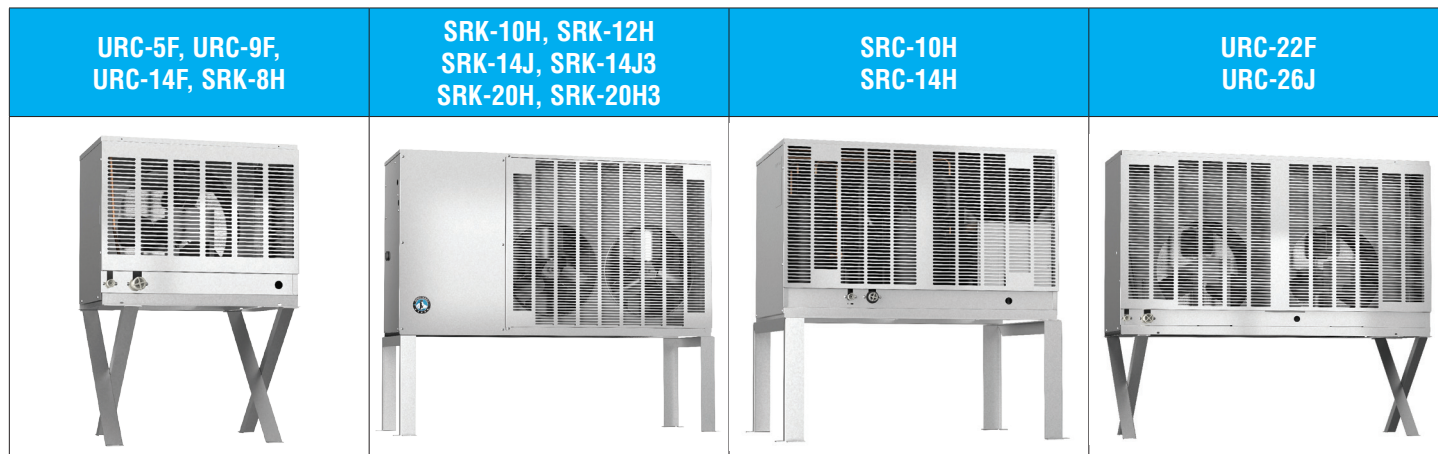

Model Number	For Use With	Electrical	Dimensions W x D x H (Height includes legs)	Shipping Weight	List F.O.B. Griffin
URC-5F	KM-515MRJ, KMD-530MRH, KM-650MRJ, FD-650MRH-C, FD-1002MRJ-C, F-1002MRJ(-C)	115/60/1	21 15/16" x 14 1/8" x 32 13/16"	60 Lbs.	\$1,500
Accessories					
Tubing Kit: R404-2046-2 - 20' Pre-charged R-404A					\$390
R404-3546-2 - 35' Pre-charged R-404A					\$490
HS-2150 - Quick-Connect Kit (not required if line set is ordered)					\$201

Model Number	For Use With	Electrical	Dimensions W x D x H (Height includes legs)	Shipping Weight	List F.O.B. Griffin
SRK-8H	KMS-830MLH	230/60/1**	35 11/16" x 25 3/8" x 37"	206 Lbs.	\$2,950
Accessories					
Tubing Kit: HS-0250 - 25' Brazing Required R-404A					\$383
HS-0251 - 35' Brazing Required R-404A					\$490
HS-0252 - 55' Brazing Required R-404A					\$615
HS-5110 - Any Serenity Condenser (SRK) - 55' Wire Kit, please call Factory.					
**3 wire with neutral for 115V For use with KMS-830MLH					

Model Number	For Use With	Electrical	Dimensions W x D x H (Height includes legs)	Shipping Weight	List F.O.B. Griffin
URC-9F	KML-700MRJ, KMD-850MRH KMD-901MRH, KM-901MRH50	115/60/1	35 11/16" x 14 1/16" x 36 1/2"	95 Lbs.	\$1,650
Accessories					
Tubing Kit: R404-2068-2 - 20' Pre-charged R-404A					\$390
R404-3568-2 - 35' Pre-charged R-404A					\$490
R404-5568-2 - 55' Pre-charged R-404A					\$630
HS-2150 - Quick-Connect Kit (not required if line set is ordered)					\$201

Model Number	For Use With	Electrical	Dimensions W x D x H (Height includes legs)	Shipping Weight	List F.O.B. Griffin
SRC-10H	FS-1001MLH-C, FS-1022MLH-C	230/60/1	28 1/4" x 25 3/8" x 34 7/8"	180 Lbs.	\$3,460
Accessories					
Tubing Kit: R404-20410 - 20' Pre-charged R-404A					\$390
R404-35410 - 35' Pre-charged R-404A					\$490
R404-55410 - 55' Pre-charged R-404A					\$630

REMOTE CONDENSER



Model Number	For Use With	Electrical	Dimensions W x D x H (Height includes legs)	Shipping Weight	List F.O.B. Griffin
SRK-10H	KMS-822MLH	230/60/1**	50" x 19 1/2" x 43"	273 Lbs.	\$3,420
Accessories					
Tubing Kit: HS-0250 - 25' Brazing Required R-404A					\$383
HS-0251 - 35' Brazing Required R-404A					\$490
HS-0252 - 55' Brazing Required R-404A					\$615
HS-0231 - Quick-Connect Kit (not required if line set is ordered)					\$212
HS-5110 - Any Serenity Condenser (SRK) - 55' Wire Kit, please call Factory.					
**3 wire with neutral for 115V					

Model Number	For Use With	Electrical	Dimensions W x D x H (Height includes legs)	Shipping Weight	List F.O.B. Griffin
SRK-12H	KMS-1122MLH	230/60/1**	50" x 19 1/2" x 43"	273 Lbs.	\$3,670
SRK-12H3	KMS-1122MLH	230/60/3	50" x 19 1/2" x 43"	273 Lbs.	\$3,780
Accessories					
Tubing Kit: R404-20810 - 20' Pre-charged R-404A					\$390
R404-35810 - 35' Pre-charged R-404A					\$525
R404-55810 - 55' Pre-charged R-404A					\$660
HS-0231 - Quick-Connect Kit (not required if line set is ordered)					\$212
HS-5110 - Any Serenity Condenser (SRK) - 55' Wire Kit, please call Factory.					
**3 wire with neutral for 115V					

Model Number	For Use With	Electrical	Dimensions W x D x H (Height includes legs)	Shipping Weight	List F.O.B. Griffin
SRC-14H	FS-1500MLH-C	230/60/1	37 7/8" x 25 1/2" x 37"	235 Lbs.	\$4,160
Accessories					
Tubing Kit: R404-20610 - 20' Pre-charged R-404A					\$390
R404-35610 - 35' Pre-charged R-404A					\$490
R404-55610 - 55' Pre-charged R-404A					\$660
**3 wire with neutral for 115V					

Model Number	For Use With	Electrical	Dimensions W x D x H (Height includes legs)	Shipping Weight	List F.O.B. Griffin
SRK-14J	KMS-1401MLJ	230/60/1**	50" x 19 1/2" x 43"	275 Lbs.	\$4,320
SRK-14J3	KMS-1401MLJ	230/60/3	50" x 19 1/2" x 43"	275 Lbs.	\$4,430
Accessories					
Tubing Kit: R404-20810 - 20' Pre-charged R-404A					\$390
R404-35810 - 35' Pre-charged R-404A					\$525
R404-55810 - 55' Pre-charged R-404A					\$660
HS-0231 - Quick-Connect Kit (not required if line set is ordered)					\$212
HS-5110 - Any Serenity Condenser (SRK) - 55' Wire Kit, please call Factory.					
**3 wire with neutral for 115V					

Model Number	For Use With	Electrical	Dimensions W x D x H (Height includes legs)	Shipping Weight	List F.O.B. Griffin
URC-14F	KM-901MRJ(3), KM-1100MRJ, KM-1301SRJ(3), KM-1340MRH(3), F-1501MRJ(-C)	115/60/1	35 11/16" x 14 1/16" x 36 1/2"	110 Lbs.	\$1,730
Accessories					
Tubing Kit: R404-2068-2 - 20' Pre-charged R-404A					\$390
R404-3568-2 - 35' Pre-charged R-404A					\$490
R404-5568-2 - 55' Pre-charged R-404A					\$630
HS-2150 - Quick-Connect Kit (not required if line set is ordered)					\$201
HS-5102 - Hail Guard Kit					\$180



REMOTE CONDENSER

Model Number	For Use With	Electrical	Dimensions W x D x H (Height includes legs)	Shipping Weight	List F.O.B. Griffin
SRK-20H SRK-20H3	KMS-2000MLH KMS-2000MLH	230/60/1** 230/60/3	59 9/16" x 19 1/2" x 45" 59 9/16" x 19 1/2" x 45"	325 Lbs. 325 Lbs.	\$8,760 \$8,880
Accessories					
Tubing Kit: HS-0243 - 25' Brazing Required R-404A					\$383
HS-0244 - 35' Brazing Required R-404A					\$490
HS-0245 - 55' Brazing Required R-404A					\$660
HS-5110 - Any Serenity Condenser (SRK) - 55' Wire Kit, please call Factory.					
**3 wire with neutral for 115V					

Model Number	For Use With	Electrical	Dimensions W x D x H (Height includes legs)	Shipping Weight	List F.O.B. Griffin
URC-22F	KM-1601MRH(3), KM-1601SRJ(3), KM-1900SRJ(3), KM-2200SRJ3, KMH-2000SRH(3), F-2001MRH(3)(-C)	115/60/1	46 3/8" x 14 1/6" x 40 1/2"	165 Lbs.	\$2,380
URC-26J	KM-2600SRJ3	115/60/1	46 3/8" x 14 1/6" x 40 1/2"	273 Lbs.	\$3,130
Accessories					
Tubing Kit: R404-20610 - 20' Pre-charged R-404A					\$390
R404-35610 - 35' Pre-charged R-404A					\$490
R404-55610 - 55' Pre-charged R-404A					\$660
HS-2150 - Quick-Connect Kit (not required if line set is ordered)					\$201
HS-5095 - Hail Guard Kit					\$170

REMOTE CONDENSER MATRIX

Line Sets - PRE-CHARGED

Remote Condenser	Ice Machines	Shipping Weight	20' Length	35' Length	55' Length
URC-5F	KM-515MRJ, KMD-530MRH, KM-650MRJ, FD-650MRH-C, FD-1001MRJ-C, F-1001MRJ(-C), F-1002MRJ(-C)	60 Lbs.	R404-2046-2	R404-3546-2	N/A
URC-9F	KML-700MRJ, KMD-850MRH	95 Lbs.	R404-2068-2	R404-3568-2	R404-5568-2
SRC-10H	FS-1001MLH-C, FS-1022MLH-C	180 Lbs.	R404-20410	R404-35410	R404-55410
SRK-12H SRK-12H3	KMS-1122MLH	275 Lbs.	R404-20810	R404-35810	R404-55810
SRC-14H	FS-1500MLH-C	235 Lbs.	R404-20610	R404-35610	R404-55610
SRK-14J SRK-14J3	KMS-1401MLJ	275 Lbs.	R404-20810	R404-35810	R404-55810
URC-14F	KM-901MRJ(3), KM-1100MRJ, KM-1301SRJ(3), KM-1340MRH(3), F-1501MRJ(-C)	110 Lbs.	R404-2068-2	R404-3568-2	R404-5568-2
URC-22F	KM-1601MRH(3), KM-1601SRJ(3), KM-1900SRJ(3), KM-2200SRJ3, KMH-2000SRH(3), F-2001MRH(3)(-C)	165 Lbs.	R404-20610	R404-35610	R404-55610
URC-26J	KM-2600SRJ3	273 Lbs.	R404-20610	R404-35610	R404-55610

Line Sets - BRAZING REQUIRED

Remote Condenser	Ice Machines	Shipping Weight	20' Length	35' Length	55' Length
SRK-8H	KMS-830MLH	206 Lbs.	HS-0250*	HS-0251*	HS-0252*
SRK-10H	KMS-822MLH	273 Lbs.	HS-0250*	HS-0251*	HS-0252*
SRK-20H SRK-20H3	KMS-2000MLH	325 Lbs.	HS-0243*	HS-0244*	HS-0245*

*Line sets require Refrigerant

HS-5110 - Any Serenity Condenser (SRK) - 55' Wire Kit, please call Factory.



WATER FILTRATION

Model Number	Description	Undercounter KMs	KM Cubers	IM Cubers	Flakers / Cubelet	DCMs
H9320-51 Use E-10 10" Prefilter	Single	AM-50, KM-61 KM-101, KM-151 KM-201, KM-260	KM-340, 515 KML-325, 500, 700 KMD-410, 460, 530 KMS-830 DKM-500	IM-200BAA IM-500SAA	All Models	All Models
H9320-52 Use E-20 20" Prefilter	Twin	N/A	KM-600, 650, 901, 1100, 1340, 1601, 1601S, 1900S, 2100S, 2200S KMD-850, 901 KMS-822, 1122, 1401 KMH-2000S	N/A	N/A	N/A
H9320-53 Use E-20 20" Prefilter	Triple	N/A	KM-1301S, 1340 KMS-2600S	N/A	N/A	N/A
H9655-11	Replacement Cartridge (1) One each					

Recommended water filter configurations based on average ice machine usage and regular filter replacement. If your operation has challenging water conditions or higher usage, then it may be necessary to use an additional filter or prefilter.

Water Filters	Description	Height of System (Manifold + Cartridge)	List F.O.B. Griffin
H9320-51	Single	18.4" H	\$355
H9320-52	Twin	19.11" H	\$606
H9320-53	Triple	19.15" H	\$845
H9655-11	Replacement Cartridge each		\$140
H9655-06	Replacement Cartridge (6 pk)		\$680

Prefilters	Description	Height of System (Manifold + Cartridge)	List F.O.B. Griffin
9534-26	E-20 Replacement Cartridges (6 pk)		\$161
9534-12	E-10 Replacement Cartridges (12 pk)		\$172
9534-20	E-20 Replacement Cartridges (20 pk)		\$355
9534-40	E-10 Replacement Cartridges (40 pk)		\$335
9795-80	E-10 Prefilter (10")		\$206
9795-90	E-20 Prefilter (20")		\$280



Triple Configuration Shown
(Single and Twin Configurations Available)



EcO₃Ice OZONE SYSTEM

Model Number	Description Flow Rate (Gal. per min.)	Undercounter KMs	KM Cubers	IM Cubers	Flakers / Cubelet	DCMs
HS-5282	Low Flow (.34 GPM)	AM-50B KM-61B KM-101B KM-151B	N/A	N/A	All Models	N/A
HS-5283	Standard Flow (1.3 GPM)	KM-201B KM-260B	KM-340M KML-325M, 500M KMD-410M DKM-500B	IM-200BAA IM-500SAA	N/A	N/A
HS-5284	Fast Flow (4.2 GPM)	N/A	KM 515M*, 600M, 650M, 901M*, 1301S, 1340M, 1601M, 1601S, 1900S, 2200S, 2600S KMD 460M, 530M, 850M, 901M KML-700M KMS 822M, 830M, 1122M, 1401M, 2000M KMH-2000S	N/A	N/A	N/A
HS-5285	Replacement Cartridge (1) One each					

Model Number	Description	Overall Dimensions Model W x D x H	List F.O.B. Griffin
HS-5282	Low Flow (.34 GPM)	3.8" x 3.6" x 8.0"	\$800
HS-5283	Standard Flow (1.3 GPM)	3.8" x 3.6" x 8.0"	\$800
HS-5284	Fast Flow (4.2 GPM)	5.98" x 3.6" x 9.28"	\$800
HS-5285	Replacement Cartridge each		\$400

The compact EcO₃Ice ozone device uses a unique, synthetic diamond-based technology that continuously treats incoming water used by ice machines, killing bacteria, yeast and mold in the ice-making path from beginning to end. Reduces biofilm build-up, greatly extending required time between cleanings. With each cycle, EcO₃Ice creates a small, safe but effective amount of pure ozone - nature's own sanitizer - which continuously treats the machine interior, storage bin, dispenser and drains.



HS-5282 - EcO₃Ice Low Flow Ozone System
HS-5283 - EcO₃Ice Standard Flow Ozone System



HS-5284
EcO₃Ice Fast Flow Ozone System



HS-5285
EcO₃Ice Ozone System
Replacement Cartridge



SUSHI CASES



Features & Benefits of HOSHIZAKI Sushi Cases

- **HNC Sushi Cases** feature eight models to choose from providing a wide selection for displaying
- NEW Energy efficient LED lights with on/off switch
- Elegant curved front glass design enhances product on display
- Condenser airflow comes in the back and out the side
- Large diameter 1" drain at front, vinyl hose included
- NSF approved thermometer
- Easy to clean ceiling
- Plate space on top of unit, 5.6 inches
- Larger front to back interior, 11 inches
- Interior floor has a radius at all four sides
- Self-contained refrigeration unit - easy to install
- Large diameter upper evaporator with tin plating
- Slightly taller doors with plastic seal at end, opposite of the handle
- Solid food plates with radius groove to fit sushi foods
- R-134a Refrigerant



HNC-210BA-R-SL

Model Number	Condenser	Refrigeration Unit Location (Front View)	Dimensions W x D x H	Electrical	Shipping Weight	List F.O.B. Griffin
HNC-120BA-R-SL	Air-Cooled	Right Side	47 1/4 x 13 5/8 x 11	115V/60/1	104 Lbs.	\$4,470
HNC-120BA-L-SL	Air-Cooled	Left Side	47 1/4 x 13 5/8 x 11	115V/60/1	104 Lbs.	\$4,470
HNC-150BA-R-SL	Air-Cooled	Right Side	59 1/16 x 13 5/8 x 11	115V/60/1	126 Lbs.	\$4,830
HNC-150BA-L-SL	Air-Cooled	Left Side	59 1/16 x 13 5/8 x 11	115V/60/1	126 Lbs.	\$4,830
HNC-180BA-R-SL	Air-Cooled	Right Side	70 7/8 x 13 5/8 x 11	115V/60/1	139 Lbs.	\$5,400
HNC-180BA-L-SL	Air-Cooled	Left Side	70 7/8 x 13 5/8 x 11	115V/60/1	139 Lbs.	\$5,400
HNC-210BA-R-SL	Air-Cooled	Right Side	82 11/16 x 13 5/8 x 11	115V/60/1	157 Lbs.	\$5,980
HNC-210BA-L-SL	Air-Cooled	Left Side	82 11/16 x 13 5/8 x 11	115V/60/1	157 Lbs.	\$5,980

"R" - Condensing Unit is on RIGHT from front view
 "L" - Condensing Unit is on LEFT from front view
 Not intended for overnight storage. NSF Standard 7

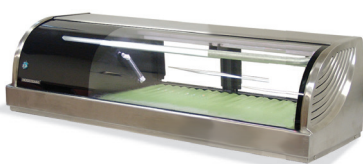

HNC-120BA-L-SL

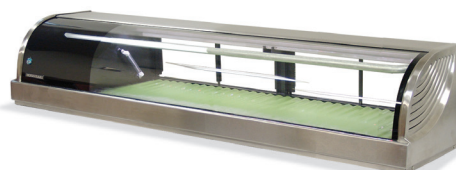

HNC-150BA-L-SL

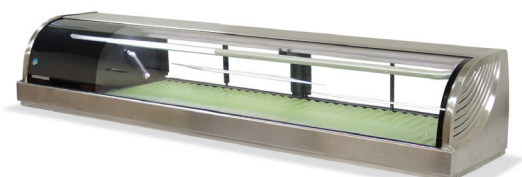

HNC-180BA-L-SL



COMMERCIAL SERIES

Features & Benefits of HOSHIZAKI Refrigeration

- Stainless steel interior and exterior front, top and sides for long life, durability and easy maintenance
- Self contained refrigeration system with energy efficient thermostatic expansion valve in upright models
- Rapid temperature cool down and recovery time
- Self-closing stainless steel doors with spring assist hinges, stay open feature and locks
- One piece, full length, extruded aluminum, flush mount door handle maximizes aisle space
- Solid state, digital controller with temperature alarms and LED display (Fahrenheit or Celsius)
- Unique ducted air distribution system, achieves a uniform cabinet temperature even when full
- Cabinets and doors are insulated with 2 to 2 3/8" foamed in place polyurethane
- Exclusive "stepped" door design to protect recessed door gasket
- Shelves are adjustable in 1" increments, allowing maximum interior flexibility
- Field reversible doors (with optional kit)
- Two and three section upright units are shipped with factory installed stem casters
- 79.63" high on casters, upright cabinet will go through standard door opening
- Enamel coated evaporator coil
- Automatic hot gas condensate disposable system, eliminates need for external drain
- Three year parts and labor warranty
- Five year parts warranty on compressor



WARRANTY



EFFECTIVE: February 1, 2018

Supersedes all previous price lists

TERMS and CONDITIONS

Prices are F.O.B. Factory. All prices and specifications are subject to change without notice. HOSHIZAKI reserves the right to determine point of shipment.

TERMS:

Terms are such as the Company may extend to the purchaser.

LOST OR DAMAGED SHIPMENTS:

Whenever seller shall deliver or cause to be delivered to a common carrier any goods ordered by consignee, whether the particular common carrier shall have been designated in the shipping instructions of the consignee or not, seller shall not be responsible for any delays or damage in shipment and the common carrier to which seller shall deliver goods shipped to the consignee is hereby declared to the agent of the consignee. Therefore it is the responsibility of the consignee to file claim with the carrier for lost or damaged shipments.

WARRANTY

All units to be free from manufacturing defects, covered by:

Commercial Series® Refrigerators & Freezers

- 3-Year - Parts & Labor on entire machine.
- 5-Year - Parts on Compressor.

Compact Undercounter Refrigerator - HR24A

- 3-Year - Parts & Labor on entire machine.

Warranty

Warranty valid in United States, Canada, Puerto Rico, & U.S. Territories only. Contact Factory for Warranty in other Countries. Refer to manufacturer's full warranty for complete details. Suggested List Prices are intended only as a guide. This does not restrict the price seller may establish due to market conditions.

AGENCY LISTINGS and MARKS





REFRIGERATION MODEL NUMBER IDENTIFICATION CODE

UPRIGHT MODELS

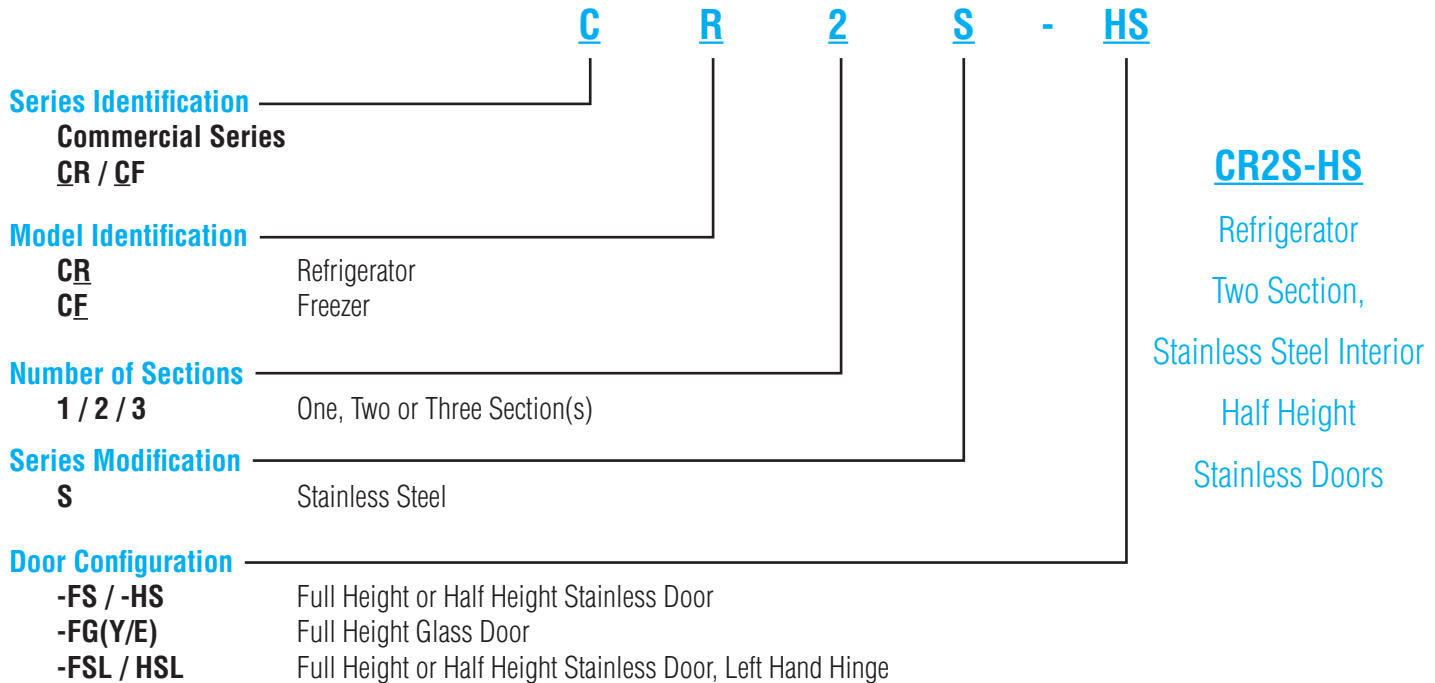

HORIZONTAL MODELS

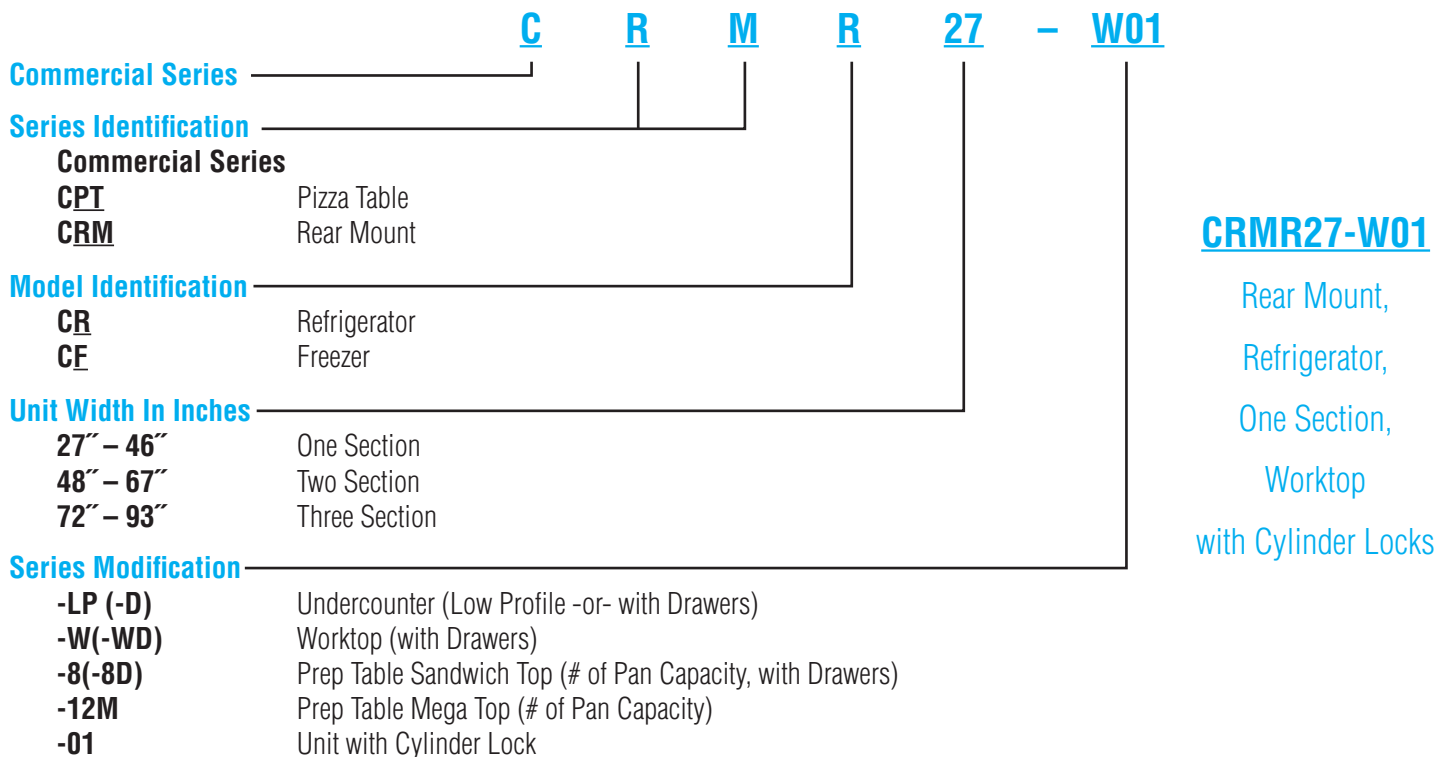



UPRIGHT REFRIGERATORS



CR1S-FS(L)
ENERGY STAR
Qualified

CR1S-HS(L)
ENERGY STAR
Qualified

CR2S-FS
ENERGY STAR
Qualified

CR2S-HS
ENERGY STAR
Qualified

CR3S-FS

CR3S-HS

- Stainless steel interior and exterior front and sides
- Self-closing stainless steel doors with spring assist hinges, stay open feature and locks
- Unique ducted air distribution system, achieves a uniform cabinet temperature even when full
- Energy efficient thermostatic expansion valve/self contained refrigeration system
- 4" Heavy duty stem casters standard

Model Number	CR1S-FS(L)	CR1S-HS(L)	CR2S-FS	CR2S-HS	CR3S-FS	CR3S-HS
Nominal Storage Capacity	22.8 ft ³	22.8 ft ³	50.5 ft ³	50.5 ft ³	73.3 ft ³	73.3 ft ³
Interior Storage Capacity (AHAM)	20.9 ft ³	20.8 ft ³	47.2 ft ³	47 ft ³	(L) 47.2 ft ³ (R) 20.9 ft ³	(L) 47.0 ft ³ (R) 20.8 ft ³
Overall Dimensions (W x D x H including 4" casters)	27.5" x 34" x 79.5"	27.5" x 34" x 79.5"	55" x 34" x 79.5"	55" x 34" x 79.5"	83" x 34" x 79.5"	83" x 34" x 79.5"
Depth with doors open at 90°	59.75"	59.75"	59.75"	59.75"	59.75"	59.75"
Interior Door opening width	22"	22"	22"	22"	22"	22"
Interior Door opening height	59.25"	27.75"	59.25"	27.75"	59.25"	27.75"
Adjustable Shelves	3	3	6	6	6 (L) / 3 (R)	6 (L) / 3 (R)
Shelf Dimensions (W x D)	21.25" x 26"	21.25" x 26"	24" x 24.75"	24" x 24.75"	(L) 24" x 24.75" (R) 21.25" x 26"	(L) 24" x 24.75" (R) 21.25" x 26"
Crated Shipping Weight	354 lbs.	354 lbs.	540 lbs.	540 lbs.	895 lbs.	895 lbs.
Crated Shipping Dimensions (W x D x H)	31.5" x 37.5" x 83"	31.5" x 37.5" x 83"	58" x 36.5" x 83"	58" x 36.5" x 83"	86" x 36.5" x 83"	86" x 36.5" x 83"
Voltage	115V/60/1	115V/60/1	115V/60/1	115V/60/1	115V/60/1	115V/60/1
Amperage (AMP)	4	4	5.8	5.8	12	12
HACR Breaker (AMP)	15	15	15	15	20	20
*Energy Consumption (kWh / day) ENERGY STAR / DOE	1.55	1.47	2.48	2.23	4.03	3.77
*Heat Rejection (BTU / hr)	401	392	660	660	595 (L) / 367 (R)	595 (L) / 367 (R)
Voltage Range	104 - 126	104 - 126	104 - 126	104 - 126	104 - 126	104 - 126
Ambient Temp. Range	45° - 100°F	45° - 100°F	45° - 100°F	45° - 100°F	45° - 100°F	45° - 100°F
Control Set Point Range	33° - 52°F	33° - 52°F	33° - 52°F	33° - 52°F	33° - 52°F	33° - 52°F
Refrigerant	R-134A	R-134A	R-134A	R-134A	R-134A	R-134A
List F.O.B. Griffin	\$5,640	\$6,870	\$7,510	\$9,300	\$13,660	\$15,610

*Based on 100°F ambient cycling at set point

See Refrigeration Accessories on pages 72-75 for options and prices





UPRIGHT REFRIGERATORS



CR1S-FGE



CR2S-FGE



CR3S-FGE

- Stainless steel interior and exterior front and sides
- Energy efficient thermostatic expansion valve/self contained refrigeration system
- Unique ducted air distribution system, achieves a uniform cabinet temperature even when full
- Glass doors are energy efficient multi pane, argon filled with locks
- FGE models come with energy efficient vertical LED lights
- 4" Heavy duty stem casters standard

Model Number	CR1S-FGE	CR2S-FGE	CR3S-FGE
Nominal Storage Capacity	23.3 ft ³	50.5 ft ³	74.3 ft ³
Interior Storage Capacity (AHAM)	20.9 ft ³	47.2 ft ³	68.1 ft ³ Total; 47.2 ft ³ (L) / 20.9 ft ³ (R)
Overall Dimensions (W x D x H including 4" casters)	27.5" x 34.75" x 79.5"	55" x 34.75" x 79.5"	83" x 34.75" x 79.5"
Depth with doors open at 90°	57.25"	57.25"	57.25"
Interior Door opening width	22"	22"	22"
Interior Door opening height	59.5"	59.5"	59.5"
Adjustable Shelves	3	6	9 Total; 6 (L) / 3 (R)
Shelf Dimensions (W x D)	21.25" x 26"	24" x 24.75"	(L) 24" x 24.75" (R) 21.25" x 26"
Crated Shipping Weight	354 lbs.	540 lbs.	895 lbs.
Crated Shipping Dimensions (W x D x H)	31.5" x 37.5" x 83"	58" x 36.5" x 83"	86" x 37.5" x 83"
Voltage	115V/60/1	115V/60/1	115V/60/1
Amperage (AMP)	4	7	12
HACR Breaker (AMP)	15	15	20
*Energy Consumption (kWh / day) ENERGY STAR / DOE	2.56	4.85	4.85 (L) / 2.56 (R)
*Heat Rejection (BTU / hr)	570	928	928 (L) / 570 (R)
Voltage Range	104 - 126	104 - 126	104 - 126
Ambient Temp. Range	45° - 100°F	45° - 100°F	45° - 100°F
Control Set Point Range	31° - 52°F	31° - 52°F	31° - 52°F
Refrigerant	R-134A	R-134A	R-134A
List F.O.B. Griffin	\$7,140	\$9,810	\$19,360

*Based on 100°F ambient cycling at set point

See Refrigeration Accessories on pages 72-75 for options and prices



UPRIGHT FREEZERS



- Stainless steel interior and exterior front and sides
- Self-closing stainless steel doors with spring assist hinges, stay open feature and locks
- Unique ducted air distribution system, achieves a uniform cabinet temperature even when full
- Energy efficient thermostatic expansion valve self contained refrigeration system
- 4" Heavy duty stem casters standard

Model Number	CF1S-FS(L)	CF1S-HS(L)	CF2S-FS	CF2S-HS	CF3S-FS	CF3S-HS
Nominal Storage Capacity	22.8 ft ³	22.8 ft ³	50.5 ft ³	50.5 ft ³	73.3 ft ³	73.3 ft ³
Interior Storage Capacity (AHAM)	20.9 ft ³	20.8 ft ³	47.2 ft ³	47.0 ft ³	68.1 ft ³	67.8 ft ³
Overall Dimensions (W x D x H including 4" casters)	27.5" x 34" x 79.5"	27.5" x 34" x 79.5"	55" x 34" x 79.5"	55" x 34" x 79.5"	83" x 34" x 79.5"	83" x 34" x 79.5"
Depth with doors open at 90°	59.75"	59.75"	59.75"	59.75"	59.75"	59.75"
Interior Door opening width	22"	22"	22"	22"	22"	22"
Interior Door opening height	59.25"	27.75"	59.25"	27.75"	59.25"	27.75"
Adjustable Shelves	3	3	6	6	6 (L) / 3 (R)	6 (L) / 3 (R)
Shelf Dimensions (W x D)	21.25" x 26"	21.25" x 26"	24" x 24.75"	24" x 24.75"	(L) 24" x 24.75" (R) 21.25" x 26"	(L) 24" x 24.75" (R) 21.25" x 26"
Crated Shipping Weight	360 lbs.	360 lbs.	545 lbs.	545 lbs.	905 lbs.	905 lbs.
Crated Shipping Dimensions (W x D x H)	31.5" x 37.5" x 83"	31.5" x 37.5" x 83"	58" x 36.5" x 83"	58" x 36.5" x 83"	86" x 36.5" x 83"	86" x 36.5" x 83"
Voltage	115V/60/1	115V/60/1	115V/60/1	115V/60/1	230/115V/60/1	230/115V/60/1
Amperage (AMP)	9.0	9.0	11	11	9.5	9.5
HACR Breaker (AMP)	15	15	15	15	20	20
*Energy Consumption (kWh / day) ENERGY STAR / DOE	5.38	5.48	10.56	9.52	15.94	15
*Heat Rejection (BTU / hr)	1429	1704	2240	2244	2148 (L) / 1589 (R)	2148 (L) / 1589 (R)
Voltage Range	104 - 126	104 - 126	104 - 126	104 - 126	104 - 126	104 - 126
Ambient Temp. Range	45° - 100°F	45° - 100°F	45° - 100°F	45° - 100°F	45° - 100°F	45° - 100°F
Control Set Point Range	-10° - +12°F	-10° - +12°F	-10° - +12°F	-10° - +12°F	-10° - +12°F	-10° - +12°F
Refrigerant	R-404A	R-404A	R-404A	R-404A	R-404A	R-404A
List F.O.B. Griffin	\$7,050	\$8,170	\$9,890	\$11,500	\$15,300	\$16,980

*Based on 100°F ambient cycling at set point

See Refrigeration Accessories on pages 72-75 for options and prices





UPRIGHT FREEZERS



CF1S-FGE



CF2S-FGE

- Stainless steel interior and exterior front and sides
- Energy efficient thermostatic expansion valve/self contained refrigeration system
- Unique ducted air distribution system, achieves a uniform cabinet temperature even when full
- Glass doors are energy efficient multi pane, argon filled with locks
- FGE models come with energy efficient vertical LED lights
- 4" Heavy duty stem casters standard

Model Number	CF1S-FGE	CF2S-FGE
Nominal Storage Capacity	23.3 ft ³	51.0 ft ³
Interior Storage Capacity (AHAM)	20.9 ft ³	47.2 ft ³
Overall Dimensions (W x D x H including 4" casters)	27.5" x 34.75" x 79.5"	55" x 34.75" x 79.5"
Depth with doors open at 90°	57.25"	57.25"
Interior Door opening width	22"	22"
Interior Door opening height	59.5"	59.5"
Adjustable Shelves	3	6
Shelf Dimensions (W x D)	21.25" x 26"	24" x 24.75"
Crated Shipping Weight	360 lbs.	545 lbs.
Crated Shipping Dimensions (W x D x H)	31.5" x 37.5" x 83"	58" x 37.5" x 83"
Voltage	115V/60/1	115V/60/1
Amperage (AMP)	9	11
HACR Breaker (AMP)	15	15
*Energy Consumption (kWh / day) ENERGY STAR / DOE	8.53	14.21
*Heat Rejection (BTU / hr)	1458	2122.5
Voltage Range	104 - 126	104 - 126
Ambient Temp. Range	45° - 80°F	45° - 80°F
Control Set Point Range	-10° - +12°F	-10° - +12°F
Refrigerant	R-404A	R-404A
List F.O.B. Griffin	\$10,580	\$14,950

*Based on 100°F ambient cycling at set point

See Refrigeration Accessories on pages 72-75 for options and prices



COMPACT UNDERCOUNTER REFRIGERATOR



HR24A
ENERGY STAR
Qualified

- Stainless steel exterior
- UL approval for outdoor use
- Energy efficient, one piece ABS interior liner
- Door is stainless steel exterior, aluminum interior and is field reversible
- Ducted air flow for even air distribution throughout cabinet
- Built-in cabinet installation with louvered trim

Model Number	HR24A
Interior Storage Capacity (AHAM)	4.0 ft ³
Overall Dimensions (W x D x H including legs)	23.4" x 24.5" x 32.7"
Depth with doors open at 90°	51.5"
Interior Door opening width	18.1"
Adjustable Shelves	3
Shelf Dimensions (W x D)	(1) 19.13" x 17" (2) 19.13" x 12"
Crated Shipping Weight	102 lbs.
Crated Shipping Dimensions (W x D x H)	24" x 26" x 38"
Voltage	115V/60/1
Amperage (AMP)	2
HACR Breaker (AMP)	15
Energy Consumption (kWh / day) ENERGY STAR / DOE	0.378
Voltage Range	104 - 127
Ambient Temp. Range	60° - 95°F
Control Set Point Range	36° - 50°F
Refrigerant	R-134A
List F.O.B. Griffin	\$2,600

ACCESSORIES:

HS-5057 - Tempered Glass Shelves, 3 pack

\$191





UNDERCOUNTER REFRIGERATORS



CRMR27(-01)
ENERGY STAR
Qualified



CRMR27-LP
ENERGY STAR
Qualified



CRMR36(-01)
ENERGY STAR
Qualified



CRMR48(-01)



CRMR60(-01)



CRMR72(-01)
ENERGY STAR
Qualified

- Stainless steel interior and exterior front, sides and top
- Engineered to maintain NSF-7 temperatures in 100°F ambient
- Field reversible doors
- Cabinet and doors are insulated with 2" foamed in place polyurethane
- 4" Stem casters standard (2.25" casters - LP model)
- Electronic controls

Model Number	CRMR27 CRMR27-01** <small>CRMR27-01 Cylinder Door Lock</small>	CRMR27-LP <small>Low Profile unit meets ADA requirements</small>	CRMR36 CRMR36-01** <small>CRMR36-01 Cylinder Door Lock</small>	CRMR48 CRMR48-01** <small>CRMR48-01 Cylinder Door Lock</small>	CRMR60 CRMR60-01** <small>CRMR60-01 Cylinder Door Lock</small>	CRMR72 CRMR72-01** <small>CRMR72-01 Cylinder Door Lock</small>
Nominal Storage Capacity	7.2 ft ³	7.2 ft ³	9.9 ft ³	13.66 ft ³	17.55 ft ³	21.25 ft ³
Interior Storage Capacity (AHAM)	6.2 ft ³	6.22 ft ³	8.7 ft ³	11.95 ft ³	16.6 ft ³	19.7 ft ³
Overall Dimensions (W x D x H including 4" casters)	27" x 30" x 33.63"	27" x 30" x 32.25"	36" x 30" x 33.63"	48" x 30" x 33.63"	60" x 30" x 33.63"	72" x 30" x 33.63"
Depth with doors open at 90°	54.5"	54.5"	56.5"	51.5"	57.5"	51.5"
Interior Door opening width	22.6"	22.6"	25.5"	19.5"	25.5"	19.5"
Interior Door opening height	22.9"	22.9"	22.9"	22.9"	22.9"	22.9"
Adjustable Shelves	1	1	1	2	2	3
Shelf Dimensions (W x D)	22.8" x 16"	22" x 16"	31" x 16"	21.3" x 16"	27.25" x 16"	22" x 16"
Crated Shipping Weight	156 lbs.	156 lbs.	187 lbs.	222 lbs.	268 lbs.	312 lbs.
Crated Shipping Dimensions (W x D x H)	31.5" x 34" x 36.5"	31.5" x 34" x 36.5"	40.5" x 34" x 36.5"	52.5" x 34" x 36.5"	62" x 34" x 36.5"	74" x 34" x 36.5"
Voltage	115V/60/1	115V/60/1	115V/60/1	115V/60/1	115V/60/1	115V/60/1
Amperage (AMP)	2.6	2.6	2.9	2.6	4.2	4.2
HACR Breaker (AMP)	15	15	15	15	15	15
Energy Consumption (kWh / day) ENERGY STAR / DOE	.65	.65	.81	1.44	2.15	2.84
Heat Rejection (BTU / hr)	180	180	242.3	327	414	539
Voltage Range	104 - 126	104 - 126	104 - 126	104 - 126	104 - 126	104 - 126
Ambient Temp. Range	45° - 100°F	45° - 100°F	45° - 100°F	45° - 100°F	45° - 100°F	45° - 100°F
Temperature Range	32° - 52°F	32° - 52°F	32° - 52°F	32° - 52°F	32° - 52°F	32° - 52°F
Refrigerant	R-134A	R-134A	R-134A	R-134A	R-134A	R-134A
List F.O.B. Griffin	\$3,380 **\$3,630	\$3,380	\$4,620 **\$4,870	\$5,080 **\$5,580	\$5,630 **\$6,130	\$6,450 **\$7,200

****SPECIAL ORDER - Please contact your local HOSHIZAKI Sales Representative for availability.**

See Refrigeration Accessories on pages 72-75 for options and prices



UNDERCOUNTER GLASS DOOR REFRIGERATOR



CRMR27-GLP01



CRMR48-GLP01

- Stainless steel interior and exterior front, sides and top
- Standard 2.25" casters (2 with brakes)
- Engineered to maintain NSF-7 temperatures in 100°F ambient
- Field reversible glass doors
- Energy efficient LED interior lights with on/off switch
- Meets ADA requirements
- Glass doors with locks are energy efficient multi pane, argon filled

Model Number	CRMR27-GLP01	CRMR48-GLP01
Nominal Storage Capacity	7.2 ft ³	13.66 ft ³
Interior Storage Capacity (AHAM)	6.22 ft ³	11.95 ft ³
Overall Dimensions (W x D x H including 2.25" casters)	27" x 32" x 31.9"	48" x 32" x 31.9"
Depth with doors open at 90°	55.5"	55.5"
Interior Door opening width	22.0"	19.5"
Interior Door opening height	22.9"	23"
Adjustable Shelves	1	2
Shelf Dimensions (W x D)	22" x 16"	21.3" x 16"
Crated Shipping Weight	184 lbs.	264 lbs.
Crated Shipping Dimensions (W x D x H)	31.5" x 34" x 36.5"	52.5" x 34" x 36.5"
Voltage	115V/60/1	115V/60/1
Amperage (AMP)	2.9	2.9
HACR Breaker (AMP)	15	15
Energy Consumption (kWh / day) ENERGY STAR / DOE	.96	1.87
Heat Rejection (BTU / hr)	196.6	393.8
Voltage Range	104 - 126	104 - 126
Ambient Temp. Range	45° - 100°F	45° - 100°F
Temperature Range	32° - 52°F	32° - 52°F
Refrigerant	R-134A	R-134A
List F.O.B. Griffin	\$5,070	\$7,550

Made to order: Please contact your local Hoshizaki Sales Representative for availability. See Refrigeration Accessories on pages 72-75 for options and prices





UNDERCOUNTER FREEZERS



CRMF27(-01)



CRMF27-LP



CRMF48(-01)



CRMF60(-01)

- Stainless steel interior and exterior front, sides and top
- Engineered to maintain NSF-7 temperatures in 100°F ambient
- Field reversible doors
- Cabinet and doors are insulated with 2" foamed in place polyurethane
- 4" Stem casters standard (2.25" casters - LP model)
- Electronic controls

Model Number	CRMF27 CRMF27-01** CRMF27-01 Cylinder Door Lock	CRMF27-LP Low Profile unit meets ADA requirements	CRMF48 CRMF48-01** CRMR48-01 Cylinder Door Lock	CRMF60 CRMF60-01** CRMR60-01 Cylinder Door Lock
Nominal Storage Capacity	7.2 ft ³	7.2 ft ³	13.66 ft ³	17.55 ft ³
Interior Storage Capacity (AHAM)	6.2 ft ³	6.22 ft ³	11.95 ft ³	16.6 ft ³
Overall Dimensions (W x D x H including 4" casters)	27" x 30" x 33.63"	27" x 30" x 32.25"	48" x 30" x 33.63"	60" x 30" x 33.63"
Depth with doors open at 90°	54.5"	54.5"	54.5"	57.5"
Interior Door opening width	22.6"	22.6"	19.5"	25.5"
Interior Door opening height	22.9"	22.9"	22.9"	22.9"
Adjustable Shelves	1	1	2	2
Shelf Dimensions (W x D)	22" x 16"	22" x 16"	21.3" x 16"	27.25" x 16"
Crated Shipping Weight	156 lbs.	156 lbs.	237 lbs.	268 lbs.
Crated Shipping Dimensions (W x D x H)	31.5" x 34" x 36.5"	31.5" x 34" x 36.5"	52.5" x 34" x 36.5"	62" x 34" x 36.5"
Voltage	115V/60/1	115V/60/1	115V/60/1	115V/60/1
Amperage (AMP)	3.4	3.4	6	6
HACR Breaker (AMP)	15	15	15	15
Energy Consumption (kWh / day) ENERGY STAR / DOE	3.1	2.66	4.34	4.86
Heat Rejection (BTU / hr)	442	442	820	821
Voltage Range	104 - 126	104 - 126	104 - 126	104 - 126
Ambient Temp. Range	45° - 100°F	45° - 100°F	45° - 100°F	45° - 100°F
Temperature Range	-10° - +10°F	-10° - +10°F	-10° - +10°F	-18° - +10°F
Refrigerant	R-134A	R-134A	R-134A	R-134A
List F.O.B. Griffin	\$4,070 **\$4,320	\$4,070	\$5,890 **\$6,400	\$7,310 **\$7,810

****SPECIAL ORDER - Please contact your local HOSHIZAKI Sales Representative for availability.**

See Refrigeration Accessories on pages 72-75 for options and prices



UNDERCOUNTER REFRIGERATORS with DRAWERS



CRMR27-D



CRMR48-D4



CRMR60-D4



CRMR72-D6

- Stainless steel interior and exterior front, sides and top
- Cabinet and drawers are insulated with 2" foamed in place polyurethane
- Engineered to maintain NSF-7 temperatures in 100°F ambient
- Heavy duty drawers with removeable gaskets
- 4" Stem casters standard
- Electronic controls

Model Number	CRMR27-D	CRMR48-D4	CRMR60-D4	CRMR72-D6
Nominal Storage Capacity	7.2 ft ³	13.66 ft ³	17.55 ft ³	21.25 ft ³
Interior Storage Capacity (AHAM)	6.2 ft ³	11.95 ft ³	16.6 ft ³	19.7 ft ³
Overall Dimensions (W x D x H including 4" casters)	27" x 30" x 33.63"	48" x 30" x 33.63"	60" x 30" x 33.63"	72" x 30" x 33.63"
Depth with Drawer Fully Open	49.25"	49.25"	49.25"	49.25"
Drawer opening width	22.6"	19.5"	25.5"	19.5"
Drawer opening height	22.9"	22.9"	22.9"	22.9"
Drawer Pan Capacity (pans by others)	(1) 12" x 20" x 6" deep pan per drawer	(1) 1/2 and (1) 1/3 size pan per drawer, 6" deep	(1) 12" x 20" x 6" deep pan per drawer	(1) 1/2 and (1) 1/3 size pan per drawer, 6" deep
Pan Capacity (# of 1/6 size x 4" deep)	N/A	N/A	N/A	N/A
Crated Shipping Weight	176 lbs.	262 lbs.	308 lbs.	372 lbs.
Crated Shipping Dimensions (W x D x H)	31.5" x 34" x 36.5"	52.5" x 34" x 36.5"	62" x 34" x 36.5"	74" x 34" x 36.5"
Voltage	115V/60/1	115V/60/1	115V/60/1	115V/60/1
Amperage (AMP)	2.6	2.6	4.2	4.2
HACR Breaker (AMP)	15	15	15	15
Energy Consumption (kWh / day) ENERGY STAR / DOE / NSF	1.4	2.3	2.15	4.5
Heat Rejection (BTU / hr)	202.8	327	473.5	647
Voltage Range	104 - 126	104 - 126	104 - 126	104 - 126
Ambient Temp. Range	45° - 100°F	45° - 100°F	45° - 100°F	45° - 100°F
Temperature Range	32° - 52°F	32° - 52°F	32° - 52°F	32° - 52°F
Refrigerant	R-134A	R-134A	R-134A	R-134A
List F.O.B. Griffin	\$5,490	\$9,130	\$10,330	\$13,170

See Refrigeration Accessories on pages 72-75 for options and prices





UNDERCOUNTER FREEZER with DRAWERS



CRMF27-D



CRMF48-D4

- Stainless steel interior and exterior front, sides and top
- Cabinet and drawers are insulated with 2" foamed in place polyurethane
- Engineered to maintain NSF-7 temperatures in 100°F ambient
- Heavy duty drawers with removeable gaskets
- 4" Stem casters standard
- Electronic controls

Model Number	CRMF27-D	CRMF48-D4
Nominal Storage Capacity	7.2 ft ³	13.66 ft ³
Interior Storage Capacity (AHAM)	6.2 ft ³	11.95 ft ³
Overall Dimensions (W x D x H including 4" casters)	27" x 30" x 33.63"	48" x 30" x 33.63"
Depth with Drawer Fully Open	49.25"	49.25"
Drawer opening width	22.6"	19.5"
Drawer opening height	22.9"	22.9"
Drawer Pan Capacity (pans by others)	(1) 12" x 20" x 6" deep pan per drawer	(1) 1/2 size and (1) 1/3 Size, 6" deep
Pan Capacity (# of 1/6 size x 4" deep)	N/A	N/A
Crated Shipping Weight	176 lbs.	262 lbs.
Crated Shipping Dimensions (W x D x H)	31.5" x 34" x 36.5"	52.5" x 34" x 36.5"
Voltage	115V/60/1	115V/60/1
Amperage (AMP)	3.4	6
HACR Breaker (AMP)	15	15
Energy Consumption (kWh / day) ENERGY STAR / DOE / NSF	3.9	6.6
Heat Rejection (BTU / hr)	560	945
Voltage Range	104 - 126	104 - 126
Ambient Temp. Range	45° - 100°F	45° - 100°F
Temperature Range	-10° - +10°F	-10° - +10°F
Refrigerant	R-134A	R-134A
List F.O.B. Griffin	\$6,580	\$9,940

See Refrigeration Accessories on pages 72-75 for options and prices



WORKTOP REFRIGERATORS



CRMR27-W(-01)
ENERGY STAR
Qualified

CRMR36-W(-01)
ENERGY STAR
Qualified

CRMR48-W(-01)

CRMR60-W(-01)

CRMR72-W(-01)
ENERGY STAR
Qualified

- Stainless steel interior and exterior front, sides and top
- Cabinet and doors are insulated with 2" foamed in place polyurethane
- Engineered to maintain NSF-7 temperatures in 100°F ambient
- Field reversible doors
- Electronic controls
- 6" Stem casters standard

Model Number	CRMR27-W CRMR27-W01** CRMR27-W01 Cylinder Door Lock	CRMR36-W CRMR36-W01** CRMR36-W01 Cylinder Door Lock	CRMR48-W CRMR48-W01** CRMR48-W01 Cylinder Door Lock	CRMR60-W CRMR60-W01** CRMR60-W01 Cylinder Door Lock	CRMR72-W CRMR72-W01** CRMR72-W01 Cylinder Door Lock
Nominal Storage Capacity	7.2 ft ³	9.9 ft ³	13.66 ft ³	17.55 ft ³	21.25 ft ³
Interior Storage Capacity (AHAM)	6.2 ft ³	8.7 ft ³	11.95 ft ³	16.6 ft ³	19.7 ft ³
Overall Dimensions (W x D x H including 6" casters)	27" x 30" x 40"	36" x 30" x 40"	48" x 30" x 40"	60" x 30" x 40"	72" x 30" x 40"
Depth with doors open at 90°	54.5"	56.5"	51.5"	57.5"	51.5"
Interior Door opening width	22.6"	25.5"	19.5"	25.5"	19.5"
Interior Door opening height	22.9"	22.9"	22.9"	22.9"	22.9"
Adjustable Shelves	1	1	2	2	3
Shelf Dimensions (W x D)	22.8" x 16"	31" x 16"	21.3" x 16"	27.25" x 16"	22" x 16"
Crated Shipping Weight	156 lbs.	187 lbs.	223 lbs.	272 lbs.	312 lbs.
Crated Shipping Dimensions (W x D x H)	31.5" x 34" x 40.5"	40.5" x 34" x 40.5"	52.5" x 34" x 40.5"	62" x 34" x 40.5"	74" x 34" x 40.75"
Voltage	115V/60/1	115V/60/1	115V/60/1	115V/60/1	115V/60/1
Amperage (AMP)	2.6	2.9	2.6	4.2	4.2
HACR Breaker (AMP)	15	15	15	15	15
Energy Consumption (kWh / day) ENERGY STAR / DOE	.65	.81	1.44	2.15	2.84
Heat Rejection (BTU / hr)	180	242.3	327	414	539
Voltage Range	104 - 126	104 - 126	104 - 126	104 - 126	104 - 126
Ambient Temp. Range	45° - 100°F	45° - 100°F	45° - 100°F	45° - 100°F	45° - 100°F
Temperature Range	32° - 52°F	32° - 52°F	32° - 52°F	32° - 52°F	32° - 52°F
Refrigerant	R-134A	R-134A	R-134A	R-134A	R-134A
List F.O.B. Griffin	\$3,540 **\$3,790	\$4,880 **\$5,130	\$5,310 **\$5,810	\$5,900 **\$6,400	\$6,760 **\$7,510

****SPECIAL ORDER - Please contact your local HOSHIZAKI Sales Representative for availability.**

See Refrigeration Accessories on pages 72-75 for options and prices





WORKTOP FREEZERS



CRMF27-W(-01)



CRMF48-W(-01)



CRMF60-W(-01)

- Stainless steel interior and exterior front, sides and top
- Cabinet and doors are insulated with 2" foamed in place polyurethane
- Engineered to maintain NSF-7 temperatures in 100°F ambient
- Field reversible doors
- Electronic controls
- 6" Stem casters standard

Model Number	CRMF27-W CRMF27-W01** CRMF27-W01 Cylinder Door Lock	CRMF48-W CRMF48-W01** CRMF48-W01 Cylinder Door Lock	CRMF60-W CRMF60-W01** CRMF60-W01 Cylinder Door Lock
Nominal Storage Capacity	7.2 ft ³	13.66 ft ³	17.55 ft ³
Interior Storage Capacity (AHAM)	6.2 ft ³	11.95 ft ³	16.6 ft ³
Overall Dimensions (W x D x H including 6" casters)	27" x 30" x 40"	48" x 30" x 40"	60" x 30" x 40"
Depth with doors open at 90°	54.5"	51.5"	57.5"
Interior Door opening width	22.6"	19.5"	25.5"
Interior Door opening height	22.9"	22.9"	22.9"
Adjustable Shelves	1	2	2
Shelf Dimensions (W x D)	22.8" x 16.0"	21.3" x 16"	27.25" x 16"
Crated Shipping Weight	156 lbs.	238 lbs.	272 lbs.
Crated Shipping Dimensions (W x D x H)	31.5" x 34" x 40.5"	52.5" x 34" x 40.5"	62" x 34" x 40.5"
Voltage	115V/60/1	115V/60/1	115V/60/1
Amperage (AMP)	3.4	6	6
HACR Breaker (AMP)	15	15	15
Energy Consumption (kWh / day) ENERGY STAR / DOE	2.66	4.34	4.86
Heat Rejection (BTU / hr)	442	820	821
Voltage Range	104 - 126	104 - 126	104 - 126
Ambient Temp. Range	45° - 100°F	45° - 100°F	45° - 100°F
Temperature Range	-10° - +10°F	-10° - +10°F	-10° - +10°F
Refrigerant	R-134A	R-134A	R-134A
List F.O.B. Griffin	\$4,150 **\$4,400	\$6,150 **\$6,650	\$7,610 **\$8,110

****SPECIAL ORDER - Please contact your local HOSHIZAKI Sales Representative for availability.**

See Refrigeration Accessories on pages 72-75 for options and prices



WORKTOP REFRIGERATORS with DRAWERS



CRMR27-WD



CRMR48-WD4



CRMR60-WD4



CRMR72-WD6

- Stainless steel interior and exterior front, sides and top
- Cabinet and drawers are insulated with 2" foamed in place polyurethane
- Engineered to maintain NSF-7 temperatures in 100°F ambient
- Heavy duty drawers with removeable gaskets
- 6" Stem casters standard
- Electronic controls

Model Number	CRMR27-WD	CRMR48-WD4	CRMR60-WD4	CRMR72-WD6
Nominal Storage Capacity	7.2 ft ³	13.66 ft ³	17.55 ft ³	21.25 ft ³
Interior Storage Capacity (AHAM)	6.2 ft ³	11.95 ft ³	16.6 ft ³	19.7 ft ³
Overall Dimensions (W x D x H including 6" casters)	27" x 30" x 40"	48" x 30" x 40"	60" x 30" x 40"	72" x 30" x 40"
Depth with Drawer Fully Open	49.25"	49.25"	49.25"	49.25"
Drawer opening width	22.6"	19.5"	25.5"	19.5"
Drawer opening height	22.9"	22.9"	22.9"	22.9"
Drawer Pan Capacity (pans by others)	(1) 12" x 20" x 6" deep pan per drawer	(1) 1/2 and (1) 1/3 size pan per drawer, 6" deep	(1) 12" x 20" x 6" deep pan per drawer	(1) 1/2 and (1) 1/3 size pan per drawer, 6" deep
Pan Capacity (# of 1/6 size x 4" deep)	N/A	N/A	N/A	N/A
Crated Shipping Weight	176 lbs.	263 lbs.	312 lbs.	377 lbs.
Crated Shipping Dimensions (W x D x H)	31.5" x 34" x 40.5"	52.5" x 34" x 40.5"	62" x 34" x 40.75"	74" x 34" x 40.75"
Voltage	115V/60/1	115V/60/1	115V/60/1	115V/60/1
Amperage (AMP)	2.6	2.6	4.2	4.2
HACR Breaker (AMP)	15	15	15	15
Energy Consumption (kWh / day) ENERGY STAR / DOE / NSF	1.4	2.3	2.15	4.5
Heat Rejection (BTU / hr)	202.8	327	473.5	647
Voltage Range	104 - 126	104 - 126	104 - 126	104 - 126
Ambient Temp. Range	45° - 100°F	45° - 100°F	45° - 100°F	45° - 100°F
Temperature Range	32° - 52°F	32° - 52°F	32° - 52°F	32° - 52°F
Refrigerant	R-134A	R-134A	R-134A	R-134A
List F.O.B. Griffin	\$5,610	\$9,290	\$10,540	\$13,630

See Refrigeration Accessories on pages 72-75 for options and prices





WORKTOP FREEZER with DRAWERS



CRMF27-WD



CRMF48-WD4

- Stainless steel interior and exterior front, sides and top
- Cabinet and drawers are insulated with 2" foamed in place polyurethane
- 6" Stem casters standard
- Heavy duty drawers with removeable gaskets
- Engineered to maintain NSF-7 temperatures in 100°F ambient
- Electronic controls

Model Number	CRMF27-WD	CRMF48-WD4
Nominal Storage Capacity	7.2 ft ³	13.66 ft ³
Interior Storage Capacity (AHAM)	6.2 ft ³	11.95 ft ³
Overall Dimensions (W x D x H including 6" casters)	27" x 30" x 40"	48" x 30" x 40"
Depth with Drawer Fully Open	49.25"	49.25"
Drawer opening width	22.6"	19.5"
Drawer opening height	22.9"	22.9"
Drawer Pan Capacity (pans by others)	(1) 12" x 20" x 6" deep pan per drawer	(1) 1/2 Size and (1) 1/3 Size, 6" deep
Pan Capacity (# of 1/6 size x 4" deep)	N/A	N/A
Crated Shipping Weight	176 lbs.	263 lbs.
Crated Shipping Dimensions (W x D x H)	31.5" x 34" x 40.5"	52.5" x 34" x 40.5"
Voltage	115V/60/1	115V/60/1
Amperage (AMP)	3.4	6
HACR Breaker (AMP)	15	15
Energy Consumption (kWh / day) ENERGY STAR / DOE	3.9	6.6
Heat Rejection (BTU / hr)	560	945
Voltage Range	104 - 126	104 - 126
Ambient Temp. Range	45° - 100°F	45° - 100°F
Temperature Range	-18° - +10°F	-10° - +10°F
Refrigerant	R-134A	R-134A
List F.O.B. Griffin	\$6,740	\$10,150

See Refrigeration Accessories on pages 72-75 for options and prices



DRAWER / DOOR COMBINATIONS



- Stainless steel interior and exterior front sides and top
- Door/Drawer configuration can be located in any cabinet section
- Engineered to maintain NSF-7 temperatures in 100°F ambient. (Certified to NSF-7 temperatures in 86°F ambient.)
- Cabinet and drawers are insulated with 2" foamed in place polyurethane
- Enamel coated evaporator coil
- Field reversible doors

Model Number	CRMR48-D2	CRMR60-D2	CRMR48-WD2	CRMR60-WD2
Nominal Storage Capacity	13.66 ft ³	17.55 ft ³	13.66 ft ³	17.55 ft ³
Interior Storage Capacity (AHAM)	11.95 ft ³	16.6 ft ³	11.95 ft ³	16.6 ft ³
Overall Dimensions (W x D x H)	48" x 30" x 33.6" (including 4" casters)	60" x 30" x 33.6" (including 4" casters)	48" x 30" x 40" (including 6" casters)	60" x 30" x 40" (including 6" casters)
Depth with Cutting Board installed	N/A	N/A	N/A	N/A
Depth with Door Open at 90°	51.5"	57.5"	51.5"	57.5"
Depth with drawer fully open	49.25"	49.25"	49.25"	49.25"
Door opening width	19.5"	25.5"	25.5"	25.5"
Door opening height	23"	23"	23"	23"
Adjustable Shelves / Shelf Dimensions (WxD)	(1) 21.25" x 16"	(1) 27.25" x 16"	(1) 21.25" x 16"	(1) 27.25" x 16"
Drawer Pan Capacity (pans by others)	(1) 1/2 and (1) 1/3 size pans, 6" deep	(1) full size pan, 6" deep	(1) 1/2 and (1) 1/3 size pans, 6" deep	(1) full size pan, 6" deep
Pan Capacity (# of 1/6 size x 4" deep)	N/A	N/A	N/A	N/A
Crated Shipping Weight	241 lbs.	288 lbs.	242 lbs.	292 lbs.
Crated Shipping Dimensions (W x D x H)	52.5" x 34" x 36.5"	62" x 34" x 36.5"	52.5" x 34" x 40.5"	62" x 34" x 40.5"
Voltage	115V/60/1	115V/60/1	115V/60/1	115V/60/1
Amperage (AMP)	2.6	4.2	2.6	4.2
HACR Breaker (AMP)	15	15	15	15
Energy Consumption (kWh / day) ENERGY STAR / DOE	2.3	3.3	2.3	3.3
Heat Rejection (BTU / hr)	327	473.5	327	473.5
Voltage Range	104 - 126	104 - 126	104 - 126	104 - 126
Ambient Temp. Range	45° - 100°F	45° - 100°F	45° - 100°F	45° - 100°F
Temperature Range	32° - 52°F	32° - 52°F	32° - 52°F	32° - 52°F
Refrigerant	R-134A	R-134A	R-134A	R-134A
List F.O.B. Griffin	\$7,240	\$7,840	\$7,430	\$8,050

Made to order: Allow 4-6 week lead time. Door and drawer configuration is customizable. See Refrigeration Accessories on pages 72-75 for options and prices





PREP TABLES - SANDWICH TOP REFRIGERATORS



CRMR27-8



CRMR36-10



CRMR48-8



CRMR48-12

- Stainless steel interior and exterior front, sides and top
- Provided with full complement of polycarbonate plastic 1/6th size pans 4" deep
- Engineered to maintain NSF-7 temperatures in 100°F ambient. (Certified to NSF-7 temperatures in 86°F ambient.)
- Cabinet and doors are insulated with 2" foamed in place polyurethane
- 1/2" x 10" Cutting board standard
- Field reversible doors

Model Number	CRMR27-8	CRMR36-10	CRMR48-8	CRMR48-12
Nominal Storage Capacity	7.21 ft ³	9.9 ft ³	13.66 ft ³	13.66 ft ³
Interior Storage Capacity (AHAM)	4.38 ft ³	8.7 ft ³	11.95 ft ³	11.95 ft ³
Overall Dimensions (W x D x H including 6" casters)	27" x 30" x 44.25"	36" x 30" x 44.25"	48" x 30" x 44.25"	48" x 30" x 44.25"
Depth with Cutting Board installed	30.7"	30.7"	30.7"	30.7"
Depth with doors open at 90°	54.5"	56.5"	51.5"	51.5"
Interior Door opening width	22.6"	25.5"	19.5"	19.5"
Interior Door opening height	22.9"	22.9"	22.9"	22.9"
Adjustable Shelves	1	1	2	2
Shelf Dimensions (W x D)	21.3" x 16"	31" x 16"	21.3" x 16"	21.3" x 16"
Pan Capacity (# of 1/6 size x 4" deep)	8	10	8	12
Crated Shipping Weight	185 lbs.	225 lbs.	222 lbs.	222 lbs.
Crated Shipping Dimensions (W x D x H)	31.5" x 34" x 45.75"	40.5" x 34" x 45.75"	52.5" x 34" x 45.75"	52.5" x 34" x 45.75"
Voltage	115V/60/1	115V/60/1	115V/60/1	115V/60/1
Amperage (AMP)	2.6	2.4	2.6	2.6
HACR Breaker (AMP)	15	15	15	15
Energy Consumption (kWh / day) ENERGY STAR / DOE	3.8	3.4	4	4
Heat Rejection (BTU / hr)	540	479.2	567	567
Voltage Range	104 - 126	104 - 126	104 - 126	104 - 126
Ambient Temp. Range	45° - 100°F	45° - 100°F	45° - 100°F	45° - 100°F
Temperature Range	32° - 52°F	32° - 52°F	32° - 52°F	32° - 52°F
Refrigerant	R-134A	R-134A	R-134A	R-134A
List F.O.B. Griffin	\$3,880	\$5,550	\$5,420	\$6,160

See Refrigeration Accessories on pages 72-75 for options and prices



PREP TABLES - SANDWICH TOP REFRIGERATORS



- Stainless steel interior and exterior front, sides and top
- Provided with full complement of polycarbonate plastic 1/6th size pans 4" deep
- Engineered to maintain NSF-7 temperatures in 100°F ambient. (Certified to NSF-7 temperatures in 86°F ambient.)
- Cabinet and doors are insulated with 2" foamed in place polyurethane
- 1/2" x 10" Cutting board standard
- Field reversible doors

Model Number	CRMR60-8	CRMR60-12	CRMR60-16	CRMR72-12	CRMR72-16	CRMR72-18
Nominal Storage Capacity	17.55 ft ³	17.55 ft ³	17.55 ft ³	21.25 ft ³	21.25 ft ³	21.25 ft ³
Interior Storage Capacity (AHAM)	16.6 ft ³	16.6 ft ³	16.6 ft ³	19.7 ft ³	19.7 ft ³	19.7 ft ³
Overall Dimensions (W x D x H including 6" casters)	60" x 30" x 44.25"	60" x 30" x 44.25"	60" x 30" x 44.25"	72" x 30" x 44.25"	72" x 30" x 44.25"	72" x 30" x 44.25"
Depth with Cutting Board installed	30.7"	30.7"	30.7"	30.7"	30.7"	30.7"
Depth with doors open at 90°	57.5"	57.5"	57.5"	51.5"	51.5"	51.5"
Interior Door opening width	25.5"	25.5"	25.5"	19.5"	19.5"	19.5"
Interior Door opening height	23"	23"	23"	22.9"	22.9"	22.9"
Adjustable Shelves	2	2	2	3	3	3
Shelf Dimensions (W x D)	22" x 16"	22" x 16"	22" x 16"	22" x 16"	22" x 16"	22" x 16"
Pan Capacity (# of 1/6 size x 4" deep)	8	12	16	12	16	18
Crated Shipping Weight	323 lbs.	323 lbs.	323 lbs.	375 lbs.	375 lbs.	375 lbs.
Crated Shipping Dimensions (W x D x H)	64.5" x 34" x 45.75"	64.5" x 34" x 45.75"	64.5" x 34" x 45.75"	74" x 34" x 45.75"	74" x 34" x 45.75"	74" x 34" x 45.75"
Voltage	115V/60/1	115V/60/1	115V/60/1	115V/60/1	115V/60/1	115V/60/1
Amperage (AMP)	5.5	5.5	5.5	6.41	6.41	6.41
HACR Breaker (AMP)	15	15	15	15	15	15
Energy Consumption (kWh / day) ENERGY STAR / DOE	4.2	4.2	4.2	4.2	4.2	4.2
Heat Rejection (BTU / hr)	596.5	596.5	596.5	911	911	911
Voltage Range	104 - 126	104 - 126	104 - 126	104 - 126	104 - 126	104 - 126
Ambient Temp. Range	45° - 100°F	45° - 100°F	45° - 100°F	45° - 100°F	45° - 100°F	45° - 100°F
Temperature Range	32° - 52°F	32° - 52°F	32° - 52°F	32° - 52°F	32° - 52°F	32° - 52°F
Refrigerant	R-134A	R-134A	R-134A	R-134A	R-134A	R-134A
List F.O.B. Griffin	\$6,752	\$6,860	\$6,370	\$7,930	\$8,010	\$7,490

See Refrigeration Accessories on pages 72-75 for options and prices



PREP TABLES - SANDWICH TOP REFRIGERATORS with DRAWERS



CRMR27-8D



CRMR48-12D4



CRMR48-12D2

- Stainless steel interior and exterior front, sides and top
- Provided with full complement of polycarbonate plastic 1/6th size pans 4" deep
- Engineered to maintain NSF-7 temperatures in 100°F ambient. (Certified to NSF-7 temperatures in 86°F ambient.)
- Cabinet and drawers are insulated with 2" foamed in place polyurethane
- 1/2" x 10" Cutting board standard
- 6" Stem casters standard

Model Number	CRMR27-8D	CRMR48-12D4	CRMR48-12D2
Nominal Storage Capacity	7.2 ft ³	13.66 ft ³	13.66 ft ³
Interior Storage Capacity (AHAM)	4.38 ft ³	11.95 ft ³	11.95 ft ³
Overall Dimensions (W x D x H including 6" casters)	27" x 30" x 44.2"	48" x 30" x 44.2"	48" x 30" x 44.25"
Depth with Cutting Board installed	30.7"	30.7"	30.7"
Depth with Door Open at 90°	N/A	N/A	51.5"
Depth with drawer fully open	49.25"	49.25"	49.25"
Door/Drawer opening width	22.6"	19.5"	19.5"
Door opening height	N/A	N/A	23"
Adjustable Shelves / Shelf Dimensions (WxD)	N/A	N/A	(1) 21.25" x 16"
Drawer Pan Capacity (pans by others)	(1) 12" x 20" x 6" deep pan per drawer	(1) 1/2 and (1) 1/3 size pan per drawer, 6" deep	(1) 1/2 and (1) 1/3 size pans 6" deep
Pan Capacity (# of 1/6 size x 4" deep)	8 (6" max. pan depth)	12 (6" max. pan depth)	12 (6" max. pan depth)
Crated Shipping Weight	205 lbs.	262 lbs.	242 lbs.
Crated Shipping Dimensions (W x D x H)	31.5" x 34" x 45.75"	52.5" x 34" x 45.75"	52.5" x 34" x 45.75"
Voltage	115V/60/1	115V/60/1	115V/60/1
Amperage (AMP)	2.6	2.6	2.6
HACR Breaker (AMP)	15	15	15
Energy Consumption (kWh / day) ENERGY STAR / DOE	1.6	4	4.0
Heat Rejection (BTU / hr)	230	567	567
Voltage Range	104 - 126	104 - 126	104 - 126
Ambient Temp. Range	45° - 100°F	45° - 100°F	45° - 100°F
Temperature Range	32° - 52°F	32° - 52°F	32° - 52°F
Refrigerant	R-134A	R-134A	R-134A
List F.O.B. Griffin	\$6,380	\$10,110	\$8,650

Made to order. Allow 4-6 week lead time. Door and drawer configuration is customizable. See Refrigeration Accessories on pages 72-75 for options and prices

PREP TABLES - MEGA TOP REFRIGERATORS



CRMR27-12M



CRMR36-15M



CRMR48-12M



CRMR48-18M

- Stainless steel interior and exterior front, sides and top
- Provided with full complement of polycarbonate plastic 1/6th size pans
- Engineered to maintain NSF-7 temperatures in 100°F ambient. (Certified to NSF-7 temperatures in 86°F ambient.)
- Cabinet and doors insulated with 2" foamed in place polyurethane
- 1/2" x 10" Cutting board standard
- 6" Stem casters standard

Model Number	CRMR27-12M	CRMR36-15M	CRMR48-12M	CRMR48-18M
Nominal Storage Capacity	7.2 ft ³	9.9 ft ³	13.66 ft ³	13.66 ft ³
Interior Storage Capacity (AHAM)	4.38 ft ³	8.7 ft ³	11.95 ft ³	11.95 ft ³
Overall Dimensions (W x D x H including 6" casters)	27" x 30" x 44.25"	36" x 30" x 44.25"	48" x 30" x 44.25"	48" x 30" x 44.25"
Depth with Cutting Board installed	37.3"	37.3"	37.3"	37.3"
Depth with doors open at 90°	54.5"	56.5"	51.5"	51.5"
Interior Door opening width	22.6"	25.5"	19.5"	19.5"
Interior Door opening height	22.9"	22.9"	22.9"	22.9"
Adjustable Shelves	1	1	2	2
Shelf Dimensions (W x D)	22" x 16"	31" x 16"	21.3" x 16"	21.3" x 16"
Pan Capacity (# of 1/6 size x 4" deep)	12	15	12	18
Crated Shipping Weight	185 lbs.	225 lbs.	222 lbs.	222 lbs.
Crated Shipping Dimensions (W x D x H)	31.5" x 34" x 45.75"	40.5" x 34" x 45.75"	52.5" x 34" x 45.75"	52.5" x 34" x 45.75"
Voltage	115V/60/1	115V/60/1	115V/60/1	115V/60/1
Amperage (AMP)	2.6	2.4	2.6	2.6
HACR Breaker (AMP)	15	15	15	15
Energy Consumption (kWh / day) ENERGY STAR / DOE	3.8	3.4	4	4
Heat Rejection (BTU / hr)	540	479.2	567	567
Voltage Range	104 - 126	104 - 126	104 - 126	104 - 126
Ambient Temp. Range	45° - 100°F	45° - 100°F	45° - 100°F	45° - 100°F
Temperature Range	32° - 52°F	32° - 52°F	32° - 52°F	32° - 52°F
Refrigerant	R-134A	R-134A	R-134A	R-134A
List F.O.B. Griffin	\$4,650	\$6,050	\$7,210	\$6,770

See Refrigeration Accessories on pages 72-75 for options and prices





PREP TABLES - MEGA TOP REFRIGERATORS



CRMR60-12M



CRMR60-18M



CRMR60-24M



CRMR72-18M



CRMR72-24M



CRMR72-30M

- Stainless steel interior and exterior front, sides and top
- Provided with full complement of polycarbonate plastic 1/6th size pans
- Engineered to maintain NSF-7 temperatures in 100°F ambient. (Certified to NSF-7 temperatures in 86°F ambient.)
- Cabinet and doors are insulated with 2" foamed in place polyurethane
- 1/2" x 10" Cutting board standard
- 6" Stem casters standard

Model Number	CRMR60-12M	CRMR60-18M	CRMR60-24M	CRMR72-18M	CRMR72-24M	CRMR72-30M
Nominal Storage Capacity	17.55 ft ³	17.55 ft ³	17.55 ft ³	21.25 ft ³	21.25 ft ³	21.25 ft ³
Interior Storage Capacity (AHAM)	16.6 ft ³	16.6 ft ³	16.6 ft ³	19.7 ft ³	19.7 ft ³	19.7 ft ³
Overall Dimensions (W x D x H including 6" casters)	60" x 30" x 44.25"	60" x 30" x 44.25"	60" x 30" x 44.25"	72" x 30" x 44.25"	72" x 30" x 44.25"	72" x 30" x 44.25"
Depth with Cutting Board installed	37.3"	37.3"	37.3"	37.3"	37.3"	37.3"
Depth with doors open at 90°	57.5"	57.5"	57.5"	51.5"	51.5"	51.5"
Interior Door opening width	25.5"	25.5"	25.5"	19.5"	19.5"	19.5"
Interior Door opening height	23"	23"	23"	22.9"	22.9"	22.9"
Adjustable Shelves	2	2	2	3	3	3
Shelf Dimensions (W x D)	27.5" x 16"	27.5" x 16"	27.5" x 16"	22" x 16"	22" x 16"	22" x 16"
Pan Capacity (# of 1/6 size x 4" deep)	12	18	24	18	24	30
Crated Shipping Weight	323 lbs.	323 lbs.	323 lbs.	375 lbs.	375 lbs.	375 lbs.
Crated Shipping Dimensions (W x D x H)	64.5" x 34" x 45.75"	64.5" x 34" x 45.75"	64.5" x 34" x 45.75"	74" x 34" x 45.75"	74" x 34" x 45.75"	74" x 34" x 45.75"
Voltage	115V/60/1	115V/60/1	115V/60/1	115V/60/1	115V/60/1	115V/60/1
Amperage (AMP)	6.0	6.0	6.0	6.0	6.0	6.0
HACR Breaker (AMP)	15	15	15	15	15	15
Energy Consumption (kWh / day) ENERGY STAR / DOE	4.2	4.2	4.2	6.5	6.5	6.5
Heat Rejection (BTU / hr)	597.5	597.5	597.5	929.3	929.3	929.3
Voltage Range	104 - 126	104 - 126	104 - 126	104 - 126	104 - 126	104 - 126
Ambient Temp. Range	45° - 100°F	45° - 100°F	45° - 100°F	45° - 100°F	45° - 100°F	45° - 100°F
Temperature Range	32° - 52°F	32° - 52°F	32° - 52°F	32° - 52°F	32° - 52°F	32° - 52°F
Refrigerant	R-134A	R-134A	R-134A	R-134A	R-134A	R-134A
List F.O.B. Griffin	\$7,930	\$8,040	\$7,510	\$9,160	\$9,320	\$8,670

See Refrigeration Accessories on pages 72-75 for options and prices

PREP TABLES - MEGA TOP REFRIGERATORS with DRAWERS



CRMR27-12MD



CRMR48-18MD4



CRMR60-24MD4



CRMR72-30MD6

- Stainless steel interior and exterior front, sides and top
- Provided with full complement of polycarbonate plastic 1/6th size pans 4" deep
- Engineered to maintain NSF-7 temperatures in 100°F ambient. (Certified to NSF-7 temperatures in 86°F ambient.)
- Cabinet and drawers are insulated with 2" foamed in place polyurethane
- 1/2" x 10" Cutting board standard
- 6" Stem casters standard

Model Number	CRMR27-12MD	CRMR48-18MD4	CRMR60-24MD4	CRMR72-30MD6
Nominal Storage Capacity	7.21 ft ³	13.66 ft ³	17.55 ft ³	21.25 ft ³
Interior Storage Capacity (AHAM)	4.38 ft ³	11.95 ft ³	16.6 ft ³	19.7 ft ³
Overall Dimensions (W x D x H including 6" casters)	27" x 30" x 44.25"	48" x 30" x 44.25"	60" x 30" x 44.25"	72" x 30" x 44.25"
Depth with Cutting Board installed	37.3"	37.3"	37.3"	37.3"
Depth with Drawer Fully Open	49.25"	49.25"	49.25"	49.25"
Drawer opening width	19.5"	19.5"	25.5"	19.5"
Drawer opening height	22.9"	22.9"	22.9"	22.9"
Drawer Pan Capacity (pans by others)	(1) 12" x 20" x 6" deep pan per drawer	(1) 1/2 and (1) 1/3 size pan per drawer, 6" deep	(1) 12" x 20" x 6" deep pan per drawer	(1) 1/2 and (1) 1/3 size pan per drawer, 6" deep
Pan Capacity (# of 1/6 size x 4" deep)	12 (6" max. pan depth)	18 (6" max. pan depth)	24 (6" max. pan depth)	30 (6" max. pan depth)
Crated Shipping Weight	205 lbs.	262 lbs.	343 lbs.	435 lbs.
Crated Shipping Dimensions (W x D x H)	31.5" x 34" x 45.75"	52.5" x 34" x 45.75"	64.5" x 34" x 45.75"	74" x 34" x 45.75"
Voltage	115V/60/1	115V/60/1	115V/60/1	115V/60/1
Amperage (AMP)	2.6	2.6	6	6
HACR Breaker (AMP)	15	15	15	15
Energy Consumption (kWh / day) ENERGY STAR / DOE	1.6	4	3.9	5.1
Heat Rejection (BTU / hr)	230	567	556	726
Voltage Range	104 - 126	104 - 126	104 - 126	104 - 126
Ambient Temp. Range	45° - 100°F	45° - 100°F	45° - 100°F	45° - 100°F
Temperature Range	32° - 52°F	32° - 52°F	32° - 52°F	32° - 52°F
Refrigerant	R-134A	R-134A	R-134A	R-134A
List F.O.B. Griffin	\$7,600	\$10,900	\$13,010	\$15,900

See Refrigeration Accessories on pages 72-75 for options and prices





PREP TABLES - MEGA TOP DRAWER / DOOR COMBINATIONS



CRMR48-18MD2



CRMR60-24MD2



CRMR72-30MD2



CRMR72-30MD4

- Stainless steel interior and exterior front sides and top
- Cabinet and drawers are insulated with 2" foamed in place polyurethane
- Engineered to maintain NSF-7 temperatures in 100°F ambient. (Certified to NSF-7 temperatures in 86°F ambient.)
- Provided with full complement of polycarbonate plastic 1/6th size pans 4" deep
- Door/Drawer configuration can be located in any cabinet section
- Field reversible doors

Model Number	CRMR48-18MD2	CRMR60-24MD2	CRMR72-30MD2	CRMR72-30MD4
Nominal Storage Capacity	13.66 ft ³	17.6 ft ³	21.2 ft ³	21.2 ft ³
Interior Storage Capacity (AHAM)	11.95 ft ³	16.6 ft ³	19.7 ft ³	19.7 ft ³
Overall Dimensions (W x D x H including 6" casters)	48" x 30" x 44.25"	60" x 30" x 44.25"	72" x 30" x 44.25"	72" x 30" x 44.25"
Depth with Cutting Board installed	37.3"	37.3"	37.3"	37.3"
Depth with Door Open at 90°	51.5"	57.5"	51.5"	51.5"
Depth with Drawer Fully Open	49.25"	49.25"	49.25"	49.25"
Door opening width	19.5"	25.5"	19.5"	19.5"
Door opening height	23"	23"	23"	23"
Adjustable Shelves / Shelf Dimensions (WxD)	(1) 21.25" x 16"	(1) 27.25" x 16"	(2) 22" x 16"	(1) 22" x 16"
Drawer Pan Capacity (pans by others)	(1) 1/2 and (1) 1/3 size pan per drawer, 6" deep	(1) full size pan 6" deep	(1) 1/2 and (1) 1/3 size pan per drawer, 6" deep	(1) 1/2 and (1) 1/3 size pan per drawer, 6" deep
Pan Capacity (# of 1/6 size x 4" deep)	18 (6" max. pan depth)	24 (6" max. pan depth)	30 (6" max. pan depth)	30 (6" max. pan depth)
Crated Shipping Weight	242 lbs.	335 lbs.	396 lbs.	417 lbs.
Crated Shipping Dimensions (W x D x H)	52.5" x 34" x 45.75"	64.5" x 34" x 45.75"	74" x 34" x 45.75"	74" x 34" x 45.75"
Voltage	115V/60/1	115V/60/1	115V/60/1	115V/60/1
Amperage (AMP)	2.6	6.0	6.0	6.0
HACR Breaker (AMP)	15	15	15	15
Energy Consumption (kWh / day) ENERGY STAR / DOE	4.0	3.9	5.1	5.1
Heat Rejection (BTU / hr)	567	556	725.5	725.5
Voltage Range	104 - 126	104 - 126	104 - 126	104 - 126
Ambient Temp. Range	45° - 100°F	45° - 100°F	45° - 100°F	45° - 100°F
Temperature Range	32° - 52°F	32° - 52°F	32° - 52°F	32° - 52°F
Refrigerant	R-134A	R-134A	R-134A	R-134A
List F.O.B. Griffin	\$9,510	\$11,680	\$12,760	\$14,270

Made to order: Allow 4-6 week lead time. Door and drawer configuration is customizable. See Refrigeration Accessories on pages 72-75 for options and prices

PREP TABLES - PIZZA REFRIGERATORS



CPT46



CPT67



CPT93

- Stainless steel interior and exterior front, sides and top
- Solid state digital controller with temperature alarms and LED display (Fahrenheit or Celsius)
- Engineered to maintain NSF-7 temperatures in 100°F ambient. (Certified to NSF-7 temperatures in 86°F ambient.)
- Adjustable ducted air distribution for rail/cabinet
- Full complement of 1/3rd size pans are standard
- 1/2" x 19" Cutting board standard

Model Number	CPT46	CPT67	CPT93
Nominal Storage Capacity	11.0 ft ³	19.9 ft ³	30.1 ft ³
Overall Dimensions (W x D x H including 6" casters)	46" x 31.25" x 43.5"	67" x 31.25" x 43.5"	93" x 31.25" x 43.5"
Depth with Cutting Board installed	35"	35"	35"
Depth with doors open at 90°	59.5"	56.75"	56.75"
Interior Door opening width	22.5"	22.5"	22.5"
Interior Door opening height	23"	23"	23"
Adjustable Shelves	2	4	6
Shelf Dimensions (W x D)	22" x 16"	24.75" x 25.5"	24.75" x 25.5"
Pan Capacity (# of 1/3 size x 4" deep)	6 (6" max. pan depth)	9 (6" max. pan depth)	12 (6" max. pan depth)
Crated Shipping Weight	284 lbs.	420 lbs.	509 lbs.
Crated Shipping Dimensions (W x D x H)	48" x 34" x 44"	69" x 34" x 44"	95" x 34" x 44.25"
Voltage	115V/60/1	115V/60/1	115V/60/1
Amperage (AMP)	3.7	5.5	5.5
HACR Breaker (AMP)	15	15	15
Energy Consumption (kWh / day) @ NSF	3.2	5	5.5
Heat Rejection (BTU / hr)	454	706	775.3
Voltage Range	104 - 126	104 - 126	104 - 126
Ambient Temp. Range	45° -100°F	45° -100°F	45° -100°F
Control Set Point Range	14° - 45°F	14° - 45°F	14° - 45°F
Refrigerant	R-134A	R-134A	R-134A
List F.O.B. Griffin	\$7,760	\$10,540	\$14,250

See Refrigeration Accessories on pages 72-75 for options and prices

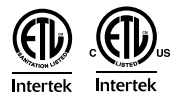



PREP TABLES - PIZZA REFRIGERATORS with DRAWERS



CPT46-D



CPT67-D4



CPT93-D6

- Stainless steel interior and exterior front, sides and top
- Solid state digital controller with temperature alarms and LED display (Fahrenheit or Celsius)
- Provided with full complement of polycarbonate plastic 1/3rd size pans 4" deep
- Engineered to maintain NSF-7 temperatures in 100°F ambient (Certified to NSF-7 temperatures in 86°F ambient.)
- Adjustable ducted air distribution for rail/cabinet
- Cabinet and drawers are insulated with 2" foamed in place polyurethane
- 1/2" x 19" Cutting board standard

Model Number	CPT46-D	CPT67-D4	CPT93-D6
Nominal Storage Capacity	11 ft ³	19.9 ft ³	30.1 ft ³
Overall Dimensions (W x D x H including casters)	46" x 32.25" x 43.5"	67" x 32.25" x 43.5"	93" x 32.25" x 43.5"
Depth with Cutting Board installed	35"	35"	35"
Depth with Drawer Fully Open	56.5"	56.5"	56.5"
Drawer opening width	22.5"	22.5"	22.5"
Drawer opening height	23"	23"	23"
Drawer Pan Capacity (pans by others)	(2) 12" x 20" x 6" deep pans	(2) 12" x 20" x 6" deep pans	(2) 12" x 20" x 6" deep pans
Pan Capacity (# of 1/3 size x 4" deep)	6	9	12
Crated Shipping Weight	337 lbs.	512 lbs.	625 lbs.
Crated Shipping Dimensions (W x D x H)	47.75" x 33.75" x 44.25"	69" x 33.75" x 44.25"	95" x 33.75" x 44.25"
Voltage	115V/60/1	115V/60/1	115V/60/1
Amperage (AMP)	3.7	5.5	5.5
HACR Breaker (AMP)	15	15	15
Energy Consumption (kWh / day) ENERGY STAR / DOE	4.3	6	5.7
Heat Rejection (BTU / hr)	605	848	803.5
Voltage Range	104 - 126	104 - 126	104 - 126
Ambient Temp. Range	45° -100°F	45° -100°F	45° -100°F
Control Set Point Range	14° - 45°F	14° - 45°F	14° - 45°F
Refrigerant	R-134A	R-134A	R-134A
List F.O.B. Griffin	\$10,030	\$15,570	\$21,320

See Refrigeration Accessories on pages 72-75 for options and prices



PREP TABLES - PIZZA DRAWER / DOOR COMBINATIONS



CPT67-D2



CPT93-D2



CPT93-D4

- Stainless steel interior and exterior front sides and top
- Provided with full complement of polycarbonate plastic 1/3rd size pans 4" deep
- Enamel coated evaporator coil
- Engineered to maintain NSF-7 temperatures in 100°F ambient. (Certified to NSF-7 temperatures in 86°F ambient.)
- Cabinet and drawers are insulated with 2" foamed in place polyurethane
- Door/Drawer configuration can be located in any cabinet section
- Field reversible doors

Model Number	CPT67-D2	CPT93-D2	CPT93-D4
Interior Storage Capacity (AHAM)	19.9 ft³	30 ft³	30 ft³
Overall Dimensions (W x D x H including 6" casters)	67" x 32.25" x 43.5"	93" x 32.25" x 43.5"	93" x 32.25" x 43.5"
Depth with Cutting Board installed	35"	35"	35"
Depth with Door Open at 90°	56.75"	56.75"	56.75"
Depth with Drawer Fully Open	56.75"	56.75"	56.75"
Door opening width	22.5"	22.5"	22.5"
Door opening height	23"	23"	23"
Adjustable Shelves / Shelf Dimensions (WxD)	(2) 24.75" x 25.5"	(2) 24.75" x 25.5"	(2) 24.75" x 25.5"
Drawer Pan Capacity (pans by others)	(2) 12" x 20" x 6" deep pans	(2) 12" x 20" x 6" deep pans	(2) 12" x 20" x 6" deep pans
Pan Capacity (# of 1/3 size x 4" deep)	9	12	12
Crated Shipping Weight	472 lbs.	547 lbs.	587 lbs.
Crated Shipping Dimensions (W x D x H)	69" x 34" x 44"	95" x 34" x 44"	95" x 34" x 44"
Voltage	115V/60/1	115V/60/1	115V/60/1
Amperage (AMP)	5.5	5.5	5.5
HACR Breaker (AMP)	15	15	15
Energy Consumption (kWh / day) ENERGY STAR / DOE	6.0	5.7	5.7
Heat Rejection (BTU / hr)	848	803.5	803.5
Voltage Range	104 - 126	104 - 126	104 - 126
Ambient Temp. Range	45° - 100°F	45° - 100°F	45° - 100°F
Temperature Range	32° - 52°F	32° - 52°F	32° - 52°F
Refrigerant	R-134A	R-134A	R-134A
List F.O.B. Griffin	\$13,400	\$17,000	\$19,460

Made to order: Allow 4-6 week lead time. Door and drawer configuration is customizable. See Refrigeration Accessories on pages 72-75 for options and prices





REFRIGERATED EQUIPMENT STANDS



CRES36



CRES49



CRES60



CRES72



CRES85



CRES98



CRES110

- Stainless steel interior and exterior front, sides and top
- 16 gauge stainless steel top with marine edge front and rear and 1" turn-up at each end
- Solid state digital controller with temperature alarms and LED display (Fahrenheit or Celsius)
- Top is provided with an exclusive, built in, HOSHIZAKI ceramic heat shield
- Standard with (4-8) 4" casters all with brakes
- Electronic controls

Model Number	CRES36	CRES49	CRES60	CRES72	CRES85	CRES98	CRES110
Overall Dimensions (W x D x H including 4" casters)	36.5" x 33.25" x 26"	49" x 33.25" x 26"	60.5" x 33.25" x 26"	72.52" x 33.25" x 26"	85" x 33.25" x 26"	98" x 33.25" x 26"	110.5" x 33.25" x 26"
Depth with Drawer Fully Open	54.25"	54.25"	54.25"	54.25"	54.25"	54.25"	54.25"
Maximum Pan Depth	6"	6"	6"	6"	6"	6"	6"
Worktop Maximum Load Capacity	700 lbs	700 lbs	700 lbs	1200 lbs	1200 lbs	1500 lbs	1500 lbs
Drawer Pan Capacity (pans by others)	(1) 12" x 20" x 6" deep pans and (1) 1/2 long pan 6" deep (pans by others)	(2) 12" x 20" x 6" deep pans	(2) 12" x 20" x 6" deep pans	(2) 12" x 20" x 6" deep pans	Left drawers: (3) 12" x 20" x 6" deep pans Right drawers: (2) 12" x 20" x 6" deep pans	(3) 12" x 20" x 6" deep pans	(3) 12" x 20" x 6" deep pans
Pan Capacity (12" x 20")	2.5	2.5	2.5	8	10	12	12
Crated Shipping Weight	260 lbs.	327 lbs.	396 lbs.	450 lbs.	540 lbs.	646 lbs.	675 lbs.
Crated Shipping Dimensions (W x D x H)	38" x 34.5" x 28.75"	50" x 34.5" x 28.75"	61.5" x 34.5" x 28.75"	74" x 34.5" x 28.75"	87" x 34.5" x 28.75"	100" x 34.5" x 28.75"	112" x 34.5" x 28.75"
Voltage	115V/60/1	115V/60/1	115V/60/1	115V/60/1	115V/60/1	115V/60/1	115V/60/1
Amperage (AMP)	3.7	3.7	3.7	4.3	4.3	4.3	4.3
HACR Breaker (AMP)	15	15	15	15	15	15	15
Energy Consumption (kWh / day) NSF	1.5	1.9	1.9	2.8	3.8	3.8	3.8
Heat Rejection (BTU / hr) @ NSF	220	275	275	398.1	538	535	535
Voltage Range	104 - 126	104 - 126	104 - 126	104 - 126	104 - 126	104 - 126	104 - 126
Ambient Temp. Range	45° - 100°F	45° - 100°F	45° - 100°F	45° - 100°F	45° - 100°F	45° - 100°F	45° - 100°F
Control Set Point Range	28° - 45°F	28° - 45°F	28° - 45°F	28° - 45°F	28° - 45°F	28° - 45°F	28° - 45°F
Refrigerant	R-134A	R-134A	R-134A	R-134A	R-134A	R-134A	R-134A
List F.O.B. Griffin	\$10,580	\$11,530	\$11,960	\$13,720	\$16,010	\$17,820	\$18,540

See Refrigeration Accessories on pages 72-75 for options and prices



GLASS DOOR MERCHANDISERS



- Electronic controller with visual and audio high and low temperature alarms
- Forced air evaporator for quick temperature pull down
- Large glass door is energy efficient low-E multi pane glass
- Door is mounted on heavy duty hinges with self-closing mechanism
- Three year parts and labor warranty & Five year compressor warranty
- 8 Foot cord and plug

Model Number	RM-10	RM-26	RM-45-SD	RM-49
Nominal Storage Capacity	10 ft ³	26 ft ³	45 ft ³	49 ft ³
Capacity	20 oz. bottles: 126 12 oz. bottles: 288	20 oz. bottles: 360 12 oz. bottles: 900	20 oz. bottles: 560 12 oz. bottles: 1260	20 oz. bottles: 630 12 oz. bottles: 1440
Overall Dimensions (W x D x H including 4" casters)	25.5" x 23" x 55.5"	30" x 29.75" x 78"	51" x 30.25" x 78.25"	60" x 29.75" x 78"
Adjustable Shelves	3	5	5 per section	5 per section
Shelf Dimensions (W x D)	21.25" x 17.5"	25.75" x 24"	23" x 20.5"	27" x 21.75"
Crated Shipping Weight	206 lbs.	340 lbs.	545 lbs.	585 lbs.
Crated Shipping Dimensions (W x D x H)	30" x 28" x 60"	34" x 34" x 82"	55" x 34" x 85"	64" x 34" x 84"
Voltage	115V/60/1	115V/60/1	115V/60/1	115V/60/1
Amperage (AMP)	3.7	4.7	11.8	7.1
HACR Breaker (AMP)	15	15	15	15
Energy Consumption (kWh / day) ENERGY STAR / DOE	1.24	2.03	3.84	4.19
Approx. Nominal Compres BTU/HR (HP)	1/5HP	1/3HP	1/2HP	1/2HP
Voltage Range	104 - 126	104 - 126	104 - 126	104 - 126
Ambient Temp. Range	60° - 86°F	60° - 86°F	60° - 86°F	60° - 86°F
Control Set Point Range	34° - 40°F	34° - 40°F	34° - 40°F	34° - 40°F
Refrigerant	R-134A	R-134A	R-134A	R-134A
List F.O.B. Griffin	\$3,930	\$5,000	\$7,380	\$7,700

See Refrigeration Accessories on pages 72-75 for options and prices





REFRIGERATION ACCESSORIES

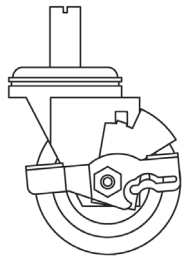

CASTERS

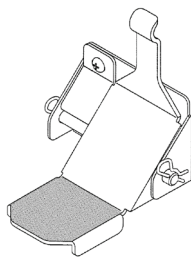

**FOOT PEDAL
DOOR OPENER**

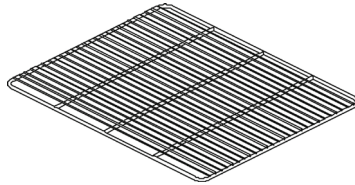

SHELVES

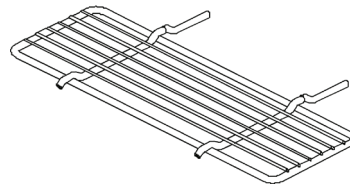

CENTER SHELVES

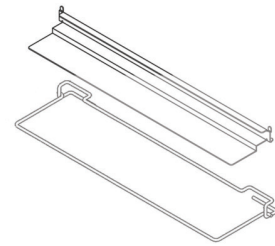

TRAY / PAN SLIDES

CASTERS & LEGS

Model Number	Description	List F.O.B. Griffin
HS-3546	4" Casters - Set of four, two with brakes (1/2 Section Uprights)	\$350
HS-3547	4" Casters - Set of six, three with brakes (3 Section Uprights)	\$550
HS-5035	4" Casters - Set of four, two with brakes (1, 2 & 3 Section Horizontal Units)	\$96
HS-5036	6" Casters - Set of four, two with brakes (1, 2 & 3 Section Horizontal Units)	\$128
HS-5037	2.25" Casters - Set of four, two with brakes (1 & 2 Section Undercounters) Casters for ADA Compliant dimensions	\$106
HS-5066	6" Legs - Set of four (Undercounters)	\$138

FOOT PEDALS

Model Number	Description	List F.O.B. Griffin
HS-3721	One Door Foot Pedal - Left Hand Hinge	\$270
HS-3722	One Door Foot Pedal - Right Hand Hinge	\$265
HS-3723	Two Door Foot Pedal	\$445

DOOR REVERSAL KIT

Model Number	Description	List F.O.B. Griffin
HS-3725	Door Reversal Kit - Half door S-Series (Right Hinge to Left Hinge) Door Reversal Kit - Full door S-Series (Left Hinge to Right Hinge)	\$106
HS-3726	Door Reversal Kit - Half door S-Series (Left Hinge to Right Hinge) Door Reversal Kit - Full door S-Series (Right Hinge to Left Hinge)	\$106
HS-5176	Door Reversal Kit - Full Glass Door S-Series FGE Models (Left Hinge to Right Hinge)	\$277
HS-5177	Door Reversal Kit - Full Glass Door S-Series FGE Models (Right Hinge to Left Hinge)	\$275

FULL SHELVES

Model Number	Description	List F.O.B. Griffin
HS-5052	Industrial Strength Epoxy Coated Wire Shelf (1 Section Uprights)	\$128
HS-5053	Industrial Strength Epoxy Coated Wire Shelf, 3 each (1 Section Uprights)	\$255
HS-5054	Industrial Strength Stainless Steel Shelf (1 Section Uprights)	\$265
HS-5047	Industrial Strength Epoxy Coated Wire Shelf (2 Section Uprights)	\$128
HS-5048	Industrial Strength Epoxy Coated Wire Shelf, 3 each (2 Section Uprights)	\$255
HS-5049	Industrial Strength Stainless Steel Shelf (2 Section Uprights)	\$288
HS-5058	Epoxy Coated Wire Shelf (All 27" and 72" Undercounters, Worktops and Prep Tables)	\$85
HS-5235	Epoxy Coated Wire Shelf (All 36" Undercounters, Worktops and Prep Tables)	\$135
HS-5059	Epoxy Coated Wire Shelf (All 48" Undercounters, Worktops and Prep Tables)	\$85
HS-5108	Epoxy Coated Wire Shelf (All 60" Undercounters, Worktops and Prep Tables)	\$106
HS-5116	Stainless Steel Shelf (All 27" and 72" Undercounters, Worktops and Prep Tables)	\$201



HS-5117	Stainless Steel Shelf (All 48" Undercounters, Worktops and Prep Tables)	\$245
HS-5118	Stainless Steel Shelf (All 60" Undercounters, Worktops and Prep Tables)	\$295
HS-5151	Epoxy Coated Wire Shelf for CPT67/93	\$170
HS-5152	Epoxy Coated Wire Shelf for CPT46	\$175
HS-5153	Stainless Steel Shelf for CPT67/93	\$308
HS-5154	Stainless Steel Shelf for CPT46	\$310

OVERSHELVES

Model Number	Description	For Use With	List F.O.B. Griffin
HS-5172[†]	Single Overshelf for 27" Cabinet	Commercial Series Undercounters, Worktops, Sandwich Top & Mega Top	\$561
HS-5236[†]	Single Overshelf for 36" Cabinet	Commercial Series Undercounters, Worktops, Sandwich Top & Mega Top	\$620
HS-5173[†]	Single Overshelf for 48" Cabinet	Commercial Series Undercounters, Worktops, Sandwich Top & Mega Top	\$643
HS-5174[†]	Single Overshelf for 60" Cabinet	Commercial Series Undercounters, Worktops, Sandwich Top & Mega Top	\$790
HS-5175[†]	Single Overshelf for 72" Cabinet	Commercial Series Undercounters, Worktops, Sandwich Top & Mega Top	\$950
HS-5163[†]	Double Overshelf for 27" Cabinet	Commercial Series Undercounters, Worktops, Sandwich Top & Mega Top	\$700
HS-5237[†]	Double Overshelf for 36" Cabinet	Commercial Series Undercounters, Worktops, Sandwich Top & Mega Top	\$780
HS-5164[†]	Double Overshelf for 48" Cabinet	Commercial Series Undercounters, Worktops, Sandwich Top & Mega Top	\$1,000
HS-5165[†]	Double Overshelf for 60" Cabinet	Commercial Series Undercounters, Worktops, Sandwich Top & Mega Top	\$1,440
HS-5166[†]	Double Overshelf for 72" Cabinet	Commercial Series Undercounters, Worktops, Sandwich Top & Mega Top	\$1,860
HS-5229**	Single Overshelf for 46" / 93" Cabinet	Commercial Series Pizza Prep Tables 93" cabinets can accommodate (2) HS-5229 Single Overshelves	\$710
HS-5231[†]	Single Overshelf for 67" Cabinet	Commercial Series Pizza Prep Tables	\$850
HS-5228**	Double Overshelf for 46" / 93" Cabinet	Commercial Series Pizza Prep Tables 93" cabinets can accommodate (2) HS-5228 Double Overshelves	\$1,075
HS-5230[†]	Double Overshelf for 67" Cabinet	Commercial Series Pizza Prep Tables	\$1,400

[†]Compatible with models manufactured since March 2016. (Serial # FXXXXXC and after)

[†]Compatible with models manufactured since January 2017. (Serial # GXXXXXA and after)

* 93" cabinets can accommodate (2) HS-5229 Single Overshelves or (2) HS-5228 Double Overshelves.

TRAY / PAN SLIDES

(16) Sets on 3" Centers per section is the recommended maximum capacity for Commercial Uprights. Units can hold as many as (24) sets on 2" Centers per section.

Model Number	Description	List F.O.B. Griffin
HS-3557	Stainless Steel Bottom Support Universal Pan Slides (1 Set)*	\$160
HS-3558	Stainless Steel Bottom Support Universal Pan Slides (4 Sets)*	\$520
HS-5092	Stainless Steel Bottom Support Wire Tray Slides (1 Set) Medium Duty for 18x26 Baker Pan (1/4 Diameter and Welded Wire)	\$118
HS-5093	Stainless Steel Bottom Support Wire Tray Slides (4 Sets) Medium Duty for 18x26 Baker Pan Only (1/4 Diameter and Welded Wire)	\$370
HS-5167	Pan Slide Conversion Kit 2-Section S Series (1 Required Per Section) *Tray / Pan slides accommodate: (1) Baker Pan: Width - 17 7/8" to 18" X Length - 25 3/4" to 26 7/8" or (2) Hotel Pans: Width - 12 7/8" to 13" X Length - 20 3/4" to 20 7/8"	\$128

CPT PAN SLIDES

Model Number	Description	List F.O.B. Griffin
HS-5315	Removable Tray Pan Rack For CPT- Accommodates (6) 18" x 26" Sheet Pans With 3" Spacing	\$810

AIR FILTERS

Model Number	Description	List F.O.B. Griffin
HS-5007	Air Filter (1 Section)	\$75
HS-5008	Air Filter (2 Section)	\$75
HS-5009	Air Filter (3 Section)	\$96



FLAT LIFT OFF COVERS

Model Number	Description	For Use With	List F.O.B. Griffin
HS-5070	Flat Lift-Off Stainless Steel Cover - 12 pan Mega Top opening	CRMR27-12M, CRMR48-12M, CRMR60-12M *CRMR60-24M, *CRMR72-24M, CRMR27-12MD *CRMR60-24MD4 (*2 of each cover required per model)	\$255
HS-5279	Flat Lift-Off Stainless Steel Cover - 15 pan Mega Top opening	CRMR36-15M	\$255
HS-5071	Flat Lift-Off Stainless Steel Cover - 18 pan Mega Top opening	CRMR48-18M, CRMR60-18M, CRMR72-18M CRMR48-18MD4	\$255
HS-5072	Flat Lift-Off Stainless Steel Cover - CRMR27-8	CRMR27-8, CRMR27-8D	\$255
HS-5073	Flat Lift-Off Stainless Steel Cover - CRMR48-8	CRMR48-8, CRMR60-8	\$255
HS-5278	Flat Lift-Off Stainless Steel Cover - 10 pan Sandwich Top opening	CRMR36-10	\$255
HS-5074	Flat Lift-Off Stainless Steel Cover - 12 pan Sandwich Top opening	CRMR48-12, CRMR48-12MD4, CRMR60-12, CRMR72-12	\$255
HS-5106	Flat Lift-Off Stainless Steel Cover - CRMR60-16, CRMR72-16	CRMR60-16, CRMR27-16	\$320
HS-5107	Flat Lift-Off Stainless Steel Cover - CRMR72-18	CRMR72-18	\$320
HS-5070 + HS-5071	Flat Lift-Off Stainless Steel Cover - 12 pan Mega Top opening Flat Lift-Off Stainless Steel Cover - 18 pan Mega Top opening	CRMR72-30M, CRMR72-30M6 (1 of each cover required per model)	\$255 (Each Cover)

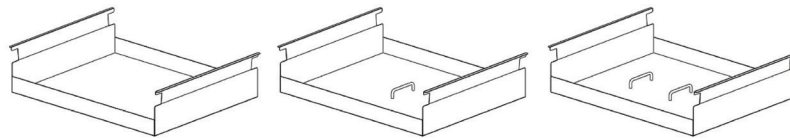

PREP GUARDS

Model Number	Description	For Use With	List F.O.B. Griffin
HS-5207	Mega Top Prep Guard - 12 Pans	-12M, -24M*, -30M†	\$260
HS-5222	Mega Top Prep Guard - 15 Pans	-15M	\$260
HS-5213	Mega Top Prep Guard - 18 Pans	-18M, -30M†	\$315

*Requires (2) HS-5207 per unit

†Requires (1) HS-5207 & (1) HS-5213 per unit

Model Number	Description	For Use With	List F.O.B. Griffin
HS-5225	Sandwich Top Prep Guard - 6 pans	-18*	\$180
HS-5220	Sandwich Top Prep Guard - CRMR27-8	CRMR27-8 ONLY	\$180
HS-5221	Sandwich Top Prep Guard - 8 pans	-8, -16†	\$180
HS-5223	Sandwich Top Prep Guard - 10 pans	-10	\$180
HS-5226	Sandwich Top Prep Guard - 12 pans	-12, -18*	\$180

*Requires (1) HS-5225 & (1) HS-5226 per unit

†Requires (2) HS-5221 per unit

COMPOSITE CUTTING BOARDS

Model Number	Description	For Use With	List F.O.B. Griffin
HS-5265	10" x 27" x 1/2" Composite Cutting Board	27" Commercial Series Sandwich Top & Mega Top	\$245
HS-5266	10" x 36" x 1/2" Composite Cutting Board	36" Commercial Series Sandwich Top & Mega Top	\$325
HS-5267	10" x 48" x 1/2" Composite Cutting Board	48" Commercial Series Sandwich Top & Mega Top	\$435
HS-5268	10" x 60" x 1/2" Composite Cutting Board	60" Commercial Series Sandwich Top & Mega Top	\$540
HS-5269	10" x 72" x 1/2" Composite Cutting Board	72" Commercial Series Sandwich Top & Mega Top	\$650
HS-5270	19" x 46" x 1/2" Composite Cutting Board	46" Commercial Series Pizza Prep Tables	\$790
HS-5271	19" x 67" x 1/2" Composite Cutting Board	67" Commercial Series Pizza Prep Table	\$1,200
HS-5272	19" x 93" x 1/2" Composite Cutting Board	93" Commercial Series Pizza Prep Table	\$1,670



GLASS DOOR MERCHANDISER ACCESSORIES

Model Number	Description	For Use With	List F.O.B. Griffin
HS-5289	Organizer Shelf With Tracks, Includes 4 Pilaster Clips	RM-10	\$135
HS-5291	Organizer Shelf With Tracks, Includes 4 Pilaster Clips	RM-26	\$150
HS-5293	Organizer Shelf With Tracks, Includes 4 Pilaster Clips	RM-45-SD	\$150
HS-5295	Organizer Shelf With Tracks, Includes 4 Pilaster Clips	RM-49	\$150
HS-5290	Price Tag Holder	RM-10	\$16
HS-5292	Price Tag Holder	RM-26	\$16
HS-5294	Price Tag Holder	RM-45-SD	\$16
HS-5296	Price Tag Holder	RM-49	\$16
HS-5316	Epoxy Shelf	RM-10	\$100
HS-5317	Epoxy Shelf	RM-26	\$130
HS-5318	Epoxy Shelf	RM-45-SD	\$130
HS-5319	Epoxy Shelf	RM-49	\$130
HS-5288	4" Casters-Set Of Four, Two With Brakes	RM-26, RM-45-SD, RM-49	\$107

MISCELLANEOUS ACCESSORIES

Model Number	Description	For Use With	List F.O.B. Griffin
HS-4007	Drawer Assembly Divider Bar (Accommodates 1/2, 1/3 and 1/6 Size Pans)	Commercial Series Undercounters, Worktops, Prep Tables with Drawers & CRES Models	\$37
HS-4009	12" Rail Divider Bar	Commercial Series Prep Table	\$22
HS-5069	Sandwich Top Rail Adapter Bar - 12.6" x 1.0" (Front to Back)	Commercial Series Sandwich Top & Mega Top	\$22
HS-5280	Full Size Pan Adapter Bar for CRMR27-8 Rail	Commercial Series Sandwich Top	\$37
HS-5281	Full Size Pan Adapter Bar for CRMR36-10 Rail	Commercial Series Sandwich Top	\$37
HS-5075	Stainless Back - 27" Horizontal Models (Factory Installed Only)	Commercial Series Sandwich Top & Mega Top	\$350
HS-5277	Stainless Back - 36" Horizontal Models (Factory Installed Only)	Commercial Series Sandwich Top & Mega Top	\$410
HS-5076	Stainless Back - 48" Horizontal Models (Factory Installed Only)	Commercial Series Sandwich Top & Mega Top	\$455
HS-5085	Stainless Back - 60" Horizontal Models (Factory Installed Only)	Commercial Series Undercounters and Worktops	\$520
HS-5086	Stainless Back - 72" Horizontal Models (Factory Installed Only)	Commercial Series Sandwich Top & Mega Top	\$600
HS-5112	Stacking Kit - CRMR27 & CRMF27	Commercial Series Undercounters	\$370
HS-5170	Stainless Back - 60" Sandwich and Mega Top Only (Factory Installed Only)	Commercial Series Sandwich Top & Mega Top	\$520
HS-5184	All Mega Top divider front to back	Commercial Series Mega Top	\$32
HS-5185	All Mega Top & Sandwich Prep 27-8 divider side to side (outer)	Commercial Series Sandwich Top & Mega Top	\$22
HS-5186	Mega Top 18M & 30M divider side to side (center)	Commercial Series Mega Top	\$22
HS-5187	Sandwich Prep 27-8 divider front to back	Commercial Series Sandwich Top	\$22
HS-5188	Sandwich Prep 48-8 and 12, 16, 18 pan openings divider front to back	Commercial Series Sandwich Top	\$22
HS-5189	Sandwich Prep 48-8 and 12, 16, 18 pan openings side to side (outer)	Commercial Series Sandwich Top	\$22
HS-5190	Sandwich Prep 12 & 16 pan openings side to side (center)	Commercial Series Sandwich Top	\$22
HS-5191	Sandwich Prep 18 pan openings side to side (outer)	Commercial Series Sandwich Top	\$37
HS-5192	Sandwich Prep 18 pan openings side to side (center)	Commercial Series Sandwich Top	\$37
HS-5234	Heated Condensate Pan Kit	Commercial Series Uprights	\$365
HS-5249	Heated Condensate Pan Kit	CPT, CRMF48/60 & CRMR60/72	\$530



HOSHIZAKI. BEYOND STRONG.

HOSHIZAKI AMERICA, INC.

618 Hwy. 74, South, Peachtree City, GA 30269

TEL 800-438-6087 | FAX 800-345-1325

hoshizakiamerica.com

Item #40067 | 2-7-18

